

SECTION **INT**  
INTERIOR

A  
B  
C  
D  
E  
F  
G  
H  
I  
INT  
K  
L  
M  
N  
O  
P

CONTENTS

<b>PRECAUTION</b> .....	3	REAR DOOR FINISHER : Removal and Installation .....	18
<b>PRECAUTIONS</b> .....	3	<b>REAR DOOR SASH INNER COVER</b> .....	21
Precaution for Supplemental Restraint System (SRS) "AIR BAG" and "SEAT BELT PRE-TENSIONER" .....	3	REAR DOOR SASH INNER COVER : Removal and Installation .....	21
Precautions for Removing Battery Terminal .....	3	<b>BODY SIDE TRIM</b> .....	23
<b>PREPARATION</b> .....	4	Exploded View .....	23
<b>PREPARATION</b> .....	4	<b>FRONT PILLAR GARNISH</b> .....	23
Special Service Tools .....	4	FRONT PILLAR GARNISH : Removal and Installation .....	24
Commercial Service Tools .....	4	<b>KICKING PLATE OUTER</b> .....	24
<b>CLIP LIST</b> .....	5	KICKING PLATE OUTER : Removal and Installation .....	25
Clip List .....	5	<b>KICKING PLATE INNER</b> .....	26
<b>SYMPTOM DIAGNOSIS</b> .....	6	KICKING PLATE INNER : Removal and Installation .....	26
<b>SQUEAK AND RATTLE TROUBLE DIAGNOSES</b> .....	6	<b>DASH SIDE FINISHER</b> .....	27
Work Flow .....	6	DASH SIDE FINISHER : Removal and Installation .....	28
Inspection Procedure .....	8	<b>BODY SIDE WELT</b> .....	28
Diagnostic Worksheet .....	10	BODY SIDE WELT : Removal and Installation .....	28
<b>REMOVAL AND INSTALLATION</b> .....	12	<b>CENTER PILLAR LOWER GARNISH</b> .....	28
<b>FRONT DOOR FINISHER</b> .....	12	CENTER PILLAR LOWER GARNISH : Removal and Installation .....	28
Exploded View .....	12	<b>CENTER PILLAR UPPER GARNISH</b> .....	29
<b>FRONT DOOR FINISHER</b> .....	13	CENTER PILLAR UPPER GARNISH : Removal and Installation .....	29
FRONT DOOR FINISHER : Removal and Installation .....	13	<b>REAR WHEEL HOUSE GARNISH</b> .....	30
<b>FRONT DOOR SASH INNER COVER</b> .....	16	REAR WHEEL HOUSE GARNISH : Removal and Installation .....	30
FRONT DOOR SASH INNER COVER : Removal and Installation .....	16	<b>REAR PILLAR FINISHER</b> .....	31
<b>REAR DOOR FINISHER</b> .....	18	REAR PILLAR FINISHER : Removal and Installation .....	31
Exploded View .....	18		
<b>REAR DOOR FINISHER</b> .....	18		

<b>REAR PARCEL SHELF FINISHER .....</b>	<b>33</b>	<b>TRUNK SIDE FINISHER .....</b>	<b>49</b>
Exploded View .....	33	TRUNK SIDE FINISHER : Removal and Installation .....	49
Removal and Installation .....	33		
<b>FLOOR TRIM .....</b>	<b>37</b>	<b>TRUNK UPPER FINISHER .....</b>	<b>50</b>
Exploded View .....	37	TRUNK UPPER FINISHER : Removal and Installation .....	50
Removal and Installation .....	37		
<b>HEADLINING .....</b>	<b>40</b>	<b>REAR SEATBACK FINISHER .....</b>	<b>50</b>
Exploded View .....	40	REAR SEATBACK FINISHER : Removal and Installation .....	50
Removal and Installation .....	42		
<b>TRUNK ROOM TRIM .....</b>	<b>46</b>	<b>REAR SEAT STRIKER COVER .....</b>	<b>52</b>
Exploded View .....	46	REAR SEAT STRIKER COVER : Removal and Installation .....	52
<b>TRUNK REAR PLATE .....</b>	<b>48</b>	<b>TRUNK LID TRIM .....</b>	<b>53</b>
TRUNK REAR PLATE : Removal and Installation..	48	Exploded View .....	53
		Removal and Installation .....	53
<b>TRUNK FRONT FINISHER .....</b>	<b>49</b>		
TRUNK FRONT FINISHER : Removal and Installation .....	49		

# PRECAUTIONS

< PRECAUTION >

## PRECAUTION

### PRECAUTIONS

#### Precaution for Supplemental Restraint System (SRS) "AIR BAG" and "SEAT BELT PRE-TENSIONER"

INFOID:000000011281417

The Supplemental Restraint System such as "AIR BAG" and "SEAT BELT PRE-TENSIONER", used along with a front seat belt, helps to reduce the risk or severity of injury to the driver and front passenger for certain types of collision. This system includes seat belt switch inputs and dual stage front air bag modules. The SRS system uses the seat belt switches to determine the front air bag deployment, and may only deploy one front air bag, depending on the severity of a collision and whether the front occupants are belted or unbelted. Information necessary to service the system safely is included in the "SRS AIR BAG" and "SEAT BELT" of this Service Manual.

#### **WARNING:**

Always observe the following items for preventing accidental activation.

- To avoid rendering the SRS inoperative, which could increase the risk of personal injury or death in the event of a collision that would result in air bag inflation, all maintenance must be performed by an authorized NISSAN/INFINITI dealer.
- Improper maintenance, including incorrect removal and installation of the SRS, can lead to personal injury caused by unintentional activation of the system. For removal of Spiral Cable and Air Bag Module, see "SRS AIR BAG".
- Never use electrical test equipment on any circuit related to the SRS unless instructed to in this Service Manual. SRS wiring harnesses can be identified by yellow and/or orange harnesses or harness connectors.

#### PRECAUTIONS WHEN USING POWER TOOLS (AIR OR ELECTRIC) AND HAMMERS

#### **WARNING:**

Always observe the following items for preventing accidental activation.

- When working near the Air Bag Diagnosis Sensor Unit or other Air Bag System sensors with the ignition ON or engine running, never use air or electric power tools or strike near the sensor(s) with a hammer. Heavy vibration could activate the sensor(s) and deploy the air bag(s), possibly causing serious injury.
- When using air or electric power tools or hammers, always switch the ignition OFF, disconnect the battery, and wait at least 3 minutes before performing any service.

#### Precautions for Removing Battery Terminal

INFOID:000000011552605

- When removing the 12V battery terminal, turn OFF the ignition switch and wait at least 30 seconds.

#### **NOTE:**

ECU may be active for several tens of seconds after the ignition switch is turned OFF. If the battery terminal is removed before ECU stops, then a DTC detection error or ECU data corruption may occur.

- For vehicles with the 2-batteries, be sure to connect the main battery and the sub battery before turning ON the ignition switch.

#### **NOTE:**

If the ignition switch is turned ON with any one of the terminals of main battery and sub battery disconnected, then DTC may be detected.

- After installing the 12V battery, always check "Self Diagnosis Result" of all ECUs and erase DTC.

#### **NOTE:**

The removal of 12V battery may cause a DTC detection error.

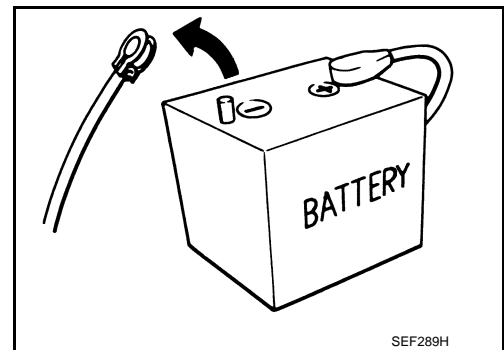

# PREPARATION

< PREPARATION >

## PREPARATION

### PREPARATION

#### Special Service Tools

INFOID:000000011281418

The actual shapes of Kent-Moore tools may differ from those of special service tools illustrated here.

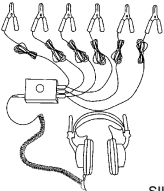
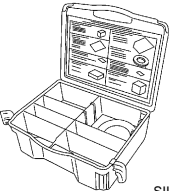
Tool number (Kent-Moore No.) Tool name	Description
<p>(J-39570) Chassis ear</p>  <p style="text-align: right;">SIIA0993E</p>	<p>Locates the noise</p>
<p>(J-50397) NISSAN Squeak and Rattle Kit</p>  <p style="text-align: right;">SIIA0994E</p>	<p>Repairs the cause of noise</p>

#### Commercial Service Tools

INFOID:000000011281419

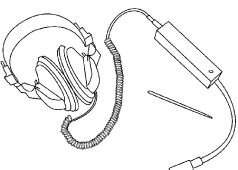
Tool name	Description
<p>Engine ear</p>  <p style="text-align: right;">SIIA0995E</p>	<p>Locates the noise</p>

# CLIP LIST

< PREPARATION >

## CLIP LIST

### Clip List

INFOID:000000011281420

Shapes	Removal & Installation	Shapes	Removal & Installation
	<p><b>Removal:</b> Remove by bending up with flat-bladed screwdrivers or clip remover.</p>		<p><b>Removal:</b></p>
	<p><b>Removal:</b> Remove with a clip remover.</p>		<p><b>Removal:</b></p>
	<p><b>Removal:</b> Push center pin to catching position. (Do not remove center pin by hitting it.)</p> <p><b>Installation:</b></p>		<p><b>Removal:</b> Holder portion of clip must be spread out to remove rod.</p>
	<p><b>Removal:</b> Remove by bending up with flat-bladed screwdrivers or clip remover.</p>		<p><b>Removal:</b></p> <ol style="list-style-type: none"> <li>Screw out with a Phillips screwdriver.</li> <li>Remove female portion with flat-bladed screwdriver.</li> </ol>
	<p><b>Removal:</b></p>		<p><b>Removal:</b></p> <p>Rotate 45° to remove.</p> <p><b>Installation:</b></p>
	<p><b>Removal:</b></p>		<p><b>Removal:</b></p>

JMJIA3734GB

A  
B  
C  
D  
E  
F  
G  
H  
I  
INT  
K  
L  
M  
N  
O  
P

# SQUEAK AND RATTLE TROUBLE DIAGNOSES

< SYMPTOM DIAGNOSIS >

## SYMPTOM DIAGNOSIS

### SQUEAK AND RATTLE TROUBLE DIAGNOSES

#### Work Flow

INFOID:000000011281421

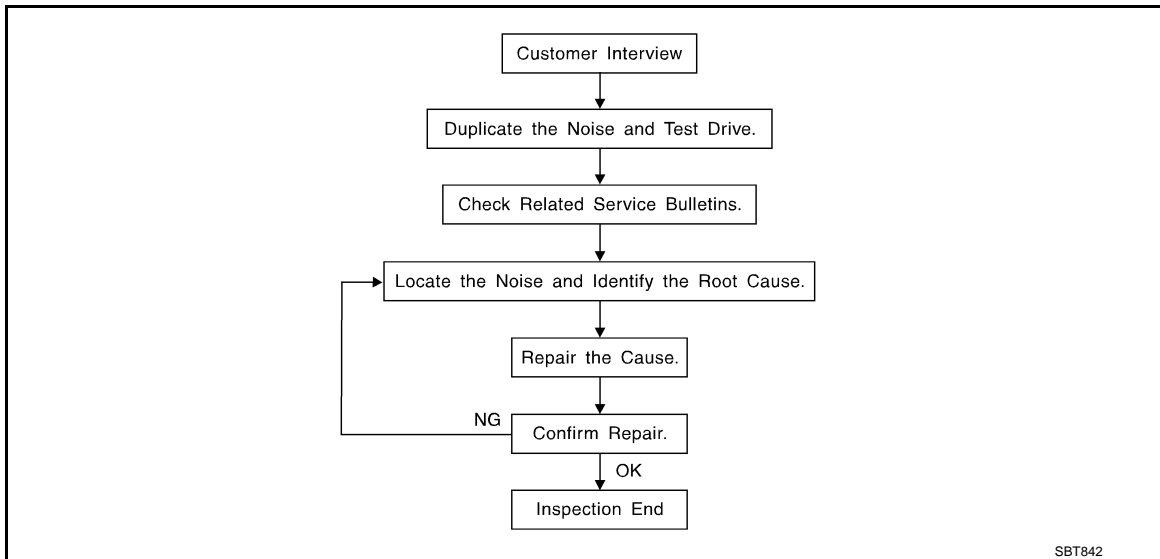

#### CUSTOMER INTERVIEW

Interview the customer if possible, to determine the conditions that exist when the noise occurs. Use the Diagnostic Worksheet during the interview to document the facts and conditions when the noise occurs and any customer comments. Refer to [INT-10. "Diagnostic Worksheet"](#). This information is necessary to duplicate the conditions that exist when the noise occurs.

- The customer may not be able to provide a detailed description or the location of the noise. Attempt to obtain all the facts and conditions that exist when the noise occurs (or does not occur).
- If there is more than one noise in the vehicle, perform a diagnosis and repair the noise that the customer is concerned about. This can be accomplished by performing a test drive with the customer.
- After identifying the type of noise, isolate the noise in terms of its characteristics. The noise characteristics are provided so that the customer, service adviser, and technician use the same language when describing the noise.
- Squeak – (Like tennis shoes on a clean floor)  
Squeak characteristics include the light contact / fast movement / brought on by road conditions / hard surfaces = high-pitched noise / softer surfaces = low-pitched noises / edge to surface = chirping
- Creak – (Like walking on an old wooden floor)  
Creak characteristics include firm contact / slow movement/twisting with a rotational movement / pitch dependent on materials / often brought on by activity.
- Rattle – (Like shaking a baby rattle)  
Rattle characteristics include fast repeated contact / vibration or similar movement / loose parts/missing clip or fastener / incorrect clearance.
- Knock – (Like a knock on a door)  
Knock characteristics include hollow sounds / sometimes repeating / often brought on by driver action.
- Tick – (Like a clock second hand)  
Tick characteristics include gentle contacting of light materials / loose components / can be caused by driver action or road conditions.
- Thump – (Heavy, muffled knock noise)  
Thump characteristics include softer knock / dull sounds often brought on by activity.
- Buzz – (Like a bumblebee)  
Buzz characteristics include high frequency rattle / firm contact.
- Often the degree of acceptable noise level varies depending upon the person. A noise that a technician may judge as acceptable may be very irritating to a customer.
- Weather conditions, especially humidity and temperature, may have a great effect on noise level.

#### DUPLICATE THE NOISE AND TEST DRIVE

# SQUEAK AND RATTLE TROUBLE DIAGNOSES

## < SYMPTOM DIAGNOSIS >

If possible, drive the vehicle with the customer until the noise is duplicated. Note any additional information on the Diagnostic Worksheet regarding the conditions or location of the noise. This information can be used to duplicate the same conditions when the repair is reconfirmed.

If the noise can be duplicated easily during the test drive, to help identify the source of the noise, try to duplicate the noise with the vehicle stopped by doing one or all of the following items:

- 1) Close a door.
  - 2) Tap or push/pull around the area where the noise appears to be coming from.
  - 3) Rev the engine.
  - 4) Use a floor jack to recreate vehicle "twist".
  - 5) At idle, apply engine load (electrical load, half-clutch on M/T models, drive position on A/T models).
  - 6) Raise the vehicle on a hoist and hit a tire with a rubber hammer.
- Drive the vehicle and attempt to duplicate the conditions the customer states exist when the noise occurs.
  - If it is difficult to duplicate the noise, drive the vehicle slowly on an undulating or rough road to stress the vehicle body.

## CHECK RELATED SERVICE BULLETINS

After verifying the customer concern or symptom, check ASIST for Technical Service Bulletins (TSBs) related to the concern or symptom.

If a TSB relates to the symptom, follow the procedure to repair the noise.

## LOCATE THE NOISE AND IDENTIFY THE ROOT CAUSE

1. Narrow down the noise to a general area. To help pinpoint the source of the noise, use a listening tool (Chassis ear: J-39570, engine ear, and mechanics stethoscope).
2. Narrow down the noise to a more specific area and identify the cause of the noise by:
  - Removing the component(s) in the area that is / are suspected to be the cause of the noise. Do not use too much force when removing clips and fasteners, otherwise clips and fasteners can be broken or lost during the repair, resulting in the creation of new noise.
  - Tapping or pushing/pulling the component(s) that is / are suspected to be the cause of the noise. Do not tap or push/pull the component(s) with excessive force, otherwise the noise is eliminated only temporarily.
  - Feeling for a vibration by hand by touching the component(s) that is / are suspected to be the cause of the noise.
  - Placing a piece of paper between components that are suspected to be the cause of the noise.
  - Looking for loose components and contact marks.  
Refer to [INT-8, "Inspection Procedure"](#).

## REPAIR THE CAUSE

- If the cause is a loose component, tighten the component securely.
- If the cause is insufficient clearance between components:
  - Separate components by repositioning or loosening and retightening the components, if possible.
  - Insulate components with a suitable insulator such as urethane pads, foam blocks, felt cloth tape, or urethane tape. A NISSAN Squeak and Rattle Kit (J-50397) is available through the authorized NISSAN Parts Department.

### **CAUTION:**

**Never use excessive force as many components are constructed of plastic and may be damaged.**

### **NOTE:**

Always check with the Parts Department for the latest parts information.

The following materials are contained in the NISSAN Squeak and Rattle Kit (J-50397) are listed on the inside cover of the kit; and can each be ordered separately as needed.

URETHANE PADS [1.5 mm (0.059 in) thick]

Insulates connectors, harness, etc.

- 76268-9E005: 100 × 135 mm (3.937 × 5.315 in)
- 76884-71L01: 60 × 85 mm (2.362 × 3.346 in)
- 76884-71L02: 15 × 25 mm (0.591 × 0.984 in)

INSULATOR (Foam blocks)

Insulates components from contact. Can be used to fill space behind a panel.

- 73982-9E000: 45 mm (1.772 in) thick, 50 × 50 mm (1.969 × 1.969 in)
- 73982-50Y00: 10 mm (0.394 in) thick, 50 × 50 mm (1.969 × 1.969 in)

INSULATOR (Light foam block)

80845-71L00: 30 mm (1.181 in) thick, 30 × 50 mm (1.181 × 1.969 in)

FELT CLOTHTAPE

# SQUEAK AND RATTLE TROUBLE DIAGNOSES

## < SYMPTOM DIAGNOSIS >

---

Used to insulate where movement does not occur. Ideal for instrument panel applications.

- 68370-4B000: 15 × 25 mm (0.591 × 0.984 in) pad
- 68239-13E00: 5 mm (0.197 in) wide tape roll

The following materials, not found in the kit, can also be used to repair squeaks and rattles.

### UHMW (TEFLON) TAPE

Insulates where slight movement is present. Ideal for instrument panel applications.

### SILICONE GREASE

Used in place of UHMW tape that is visible or does not fit. Only lasts a few months.

### SILICONE SPRAY

Used when grease cannot be applied.

### DUCT TAPE

Used to eliminate movement.

## CONFIRM THE REPAIR

After repair is complete, test drive the vehicle to confirm that the cause of noise is repaired by test driving the vehicle. Operate the vehicle under the same conditions as when the noise originally occurred. Refer to the notes on the Diagnostic Worksheet.

## Inspection Procedure

INFOID:000000011281422

Refer to Table of Contents for specific component removal and installation information.

## INSTRUMENT PANEL

Most incidents are caused by contact and movement between:

1. The cluster lid A and instrument panel
2. Acrylic lens and combination meter housing
3. Instrument panel to front pillar garnish
4. Instrument panel to windshield
5. Instrument panel mounting pins
6. Wiring harnesses behind the combination meter
7. A/C defroster duct and duct joint

These incidents can usually be located by tapping or moving the components to duplicate the noise or by pressing on the components while driving to stop the noise. Most of these incidents can be repaired by applying felt cloth tape or silicon spray (in hard to reach areas). Urethane pads can be used to insulate wiring harness.

### **CAUTION:**

**Never use silicone spray to isolate a squeak or rattle. If the area is saturated with silicone, the recheck of repair becomes impossible.**

## CENTER CONSOLE

Components to check include:

1. Shifter assembly cover to finisher
2. A/C control unit and cluster lid C
3. Wiring harnesses behind audio and A/C control unit

The instrument panel repair and isolation procedures also apply to the center console.

## DOORS

Check the following items:

1. Finisher and inner panel making a slapping noise
2. Inside handle escutcheon connection to door finisher
3. Wiring harnesses tapping
4. Door striker out of alignment causing a popping noise on starts and stops

Tapping, moving the components, or pressing on them while driving to duplicate the conditions can isolate many of these incidents. The areas can usually be insulated with felt cloth tape or insulator foam blocks from the NISSAN Squeak and Rattle Kit (J-50397) to repair the noise.

## TRUNK

Trunk noises are often caused by a loose jack or loose items put into the trunk by the customer.

In addition check for the following items:



# SQUEAK AND RATTLE TROUBLE DIAGNOSES

## < SYMPTOM DIAGNOSIS >

---

1. Trunk lid dumpers out of adjustment
2. Trunk lid striker out of adjustment
3. Trunk lid torsion bars knocking together
4. A loose license plate or bracket

Most of these incidents can be repaired by adjusting, securing, or insulating the item(s) or component(s) causing the noise.

## SUNROOF/HEADLINING

Noises in the sunroof / headlining area can often be traced to one of the following items:

1. Sunroof lid, rail, linkage, or seals making a rattle or light knocking noise
2. Sunvisor shaft shaking in the holder
3. Front or rear windshield touching headlining and squeaking

Again, pressing on the components to stop the noise while duplicating the conditions can isolate most of these incidents. Repairs usually consist of insulating with felt cloth tape.

## SEATS

When isolating seat noise it is important to note the position the seat is in and the load placed on the seat when the noise occurs. These conditions should be duplicated when verifying and isolating the cause of the noise.

Causes of seat noise include:

1. Headrest rods and holder
2. A squeak between the seat pad cushion and frame
3. The rear seatback lock and bracket

These noises can be isolated by moving or pressing on the suspected components while duplicating the conditions under which the noise occurs. Most of these incidents can be repaired by repositioning the component or applying urethane tape to the contact area.

## UNDERHOOD

Some interior noise may be caused by components under the hood or on the engine wall. The noise is then transmitted into the passenger compartment.

Causes of transmitted underhood noise include:

1. Any component mounted to the engine wall
2. Components that pass through the engine wall
3. Engine wall mounts and connectors
4. Loose radiator mounting pins
5. Hood bumpers out of adjustment
6. Hood striker out of adjustment

These noises can be difficult to isolate since they cannot be reached from the interior of the vehicle. The best method is to secure, move, or insulate one component at a time and test drive the vehicle. Also, engine RPM or load can be changed to isolate the noise. Repairs can usually be made by moving, adjusting, securing, or insulating the component causing the noise.

A  
B  
C  
D  
E  
F  
G  
H  
I  
INT  
K  
L  
M  
N  
O  
P

# SQUEAK AND RATTLE TROUBLE DIAGNOSES

< SYMPTOM DIAGNOSIS >

## Diagnostic Worksheet

INFOID:000000011281423



### SQUEAK & RATTLE DIAGNOSTIC WORKSHEET

Dear Infiniti Customer:

We are concerned about your satisfaction with your Infiniti vehicle. Repairing a squeak or rattle sometimes can be very difficult. To help us fix your Infiniti right the first time, please take a moment to note the area of the vehicle where the squeak or rattle occurs and under what conditions. You may be asked to take a test drive with a service consultant or technician to ensure we confirm the noise you are hearing.

#### I. WHERE DOES THE NOISE COME FROM? (circle the area of the vehicle)

The illustrations are for reference only, and may not reflect the actual configuration of your vehicle.

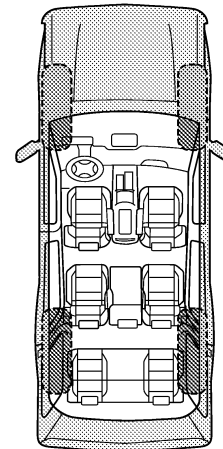
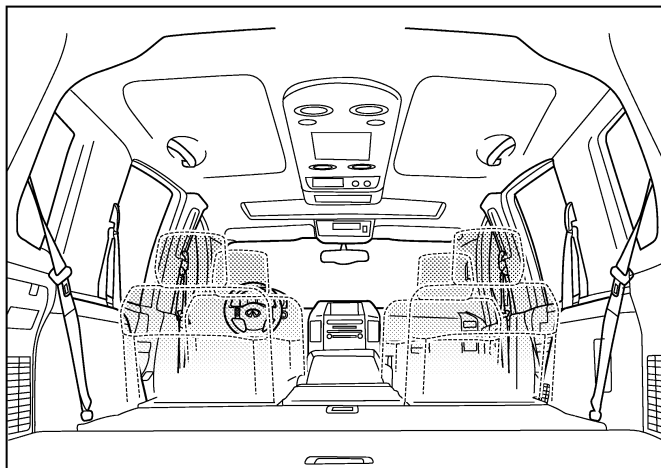
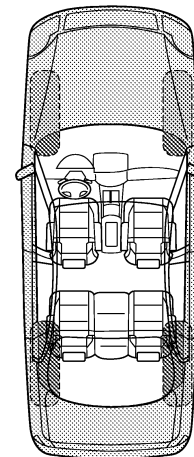
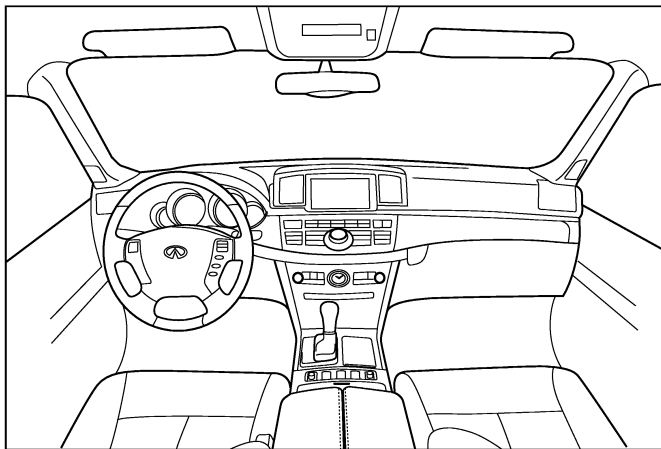

Continue to page 2 of the worksheet and briefly describe the location of the noise or rattle. In addition, please indicate the conditions which are present when the noise occurs.

PIIB8741E

# SQUEAK AND RATTLE TROUBLE DIAGNOSES

< SYMPTOM DIAGNOSIS >

## SQUEAK & RATTLE DIAGNOSTIC WORKSHEET - page 2

Briefly describe the location where the noise occurs:

---

---

### II. WHEN DOES IT OCCUR? (please check the boxes that apply)

- |   |  |
|---|--|
| <input type="checkbox"/> anytime                      | <input type="checkbox"/> after sitting out in the rain |
| <input type="checkbox"/> 1st time in the morning      | <input type="checkbox"/> when it is raining or wet     |
| <input type="checkbox"/> only when it is cold outside | <input type="checkbox"/> dry or dusty conditions       |
| <input type="checkbox"/> only when it is hot outside  | <input type="checkbox"/> other:                        |

### III. WHEN DRIVING:

- through driveways
- over rough roads
- over speed bumps
- only about \_\_\_\_ mph
- on acceleration
- coming to a stop
- on turns: left, right or either (circle)
- with passengers or cargo
- other: \_\_\_\_\_
- after driving \_\_\_\_ miles or \_\_\_\_ minutes

### IV. WHAT TYPE OF NOISE

- squeak (like tennis shoes on a clean floor)
- creak (like walking on an old wooden floor)
- rattle (like shaking a baby rattle)
- knock (like a knock at the door)
- tick (like a clock second hand)
- thump (heavy, muffled knock noise)
- buzz (like a bumble bee)

### TO BE COMPLETED BY DEALERSHIP PERSONNEL

#### Test Drive Notes:

---

---

---

	YES	NO	Initials of person performing
Vehicle test driven with customer	<input type="checkbox"/>	<input type="checkbox"/>	_____
- Noise verified on test drive	<input type="checkbox"/>	<input type="checkbox"/>	_____
- Noise source located and repaired	<input type="checkbox"/>	<input type="checkbox"/>	_____
- Follow up test drive performed to confirm repair	<input type="checkbox"/>	<input type="checkbox"/>	_____

VIN: \_\_\_\_\_ Customer Name: \_\_\_\_\_  
W.O.# \_\_\_\_\_ Date: \_\_\_\_\_

This form must be attached to Work Order

PIIB8742E

A  
B  
C  
D  
E  
F  
G  
H  
I  
INT  
K  
L  
M  
N  
O  
P

# FRONT DOOR FINISHER

< REMOVAL AND INSTALLATION >

## REMOVAL AND INSTALLATION

### FRONT DOOR FINISHER

Exploded View

INFOID:000000011281424

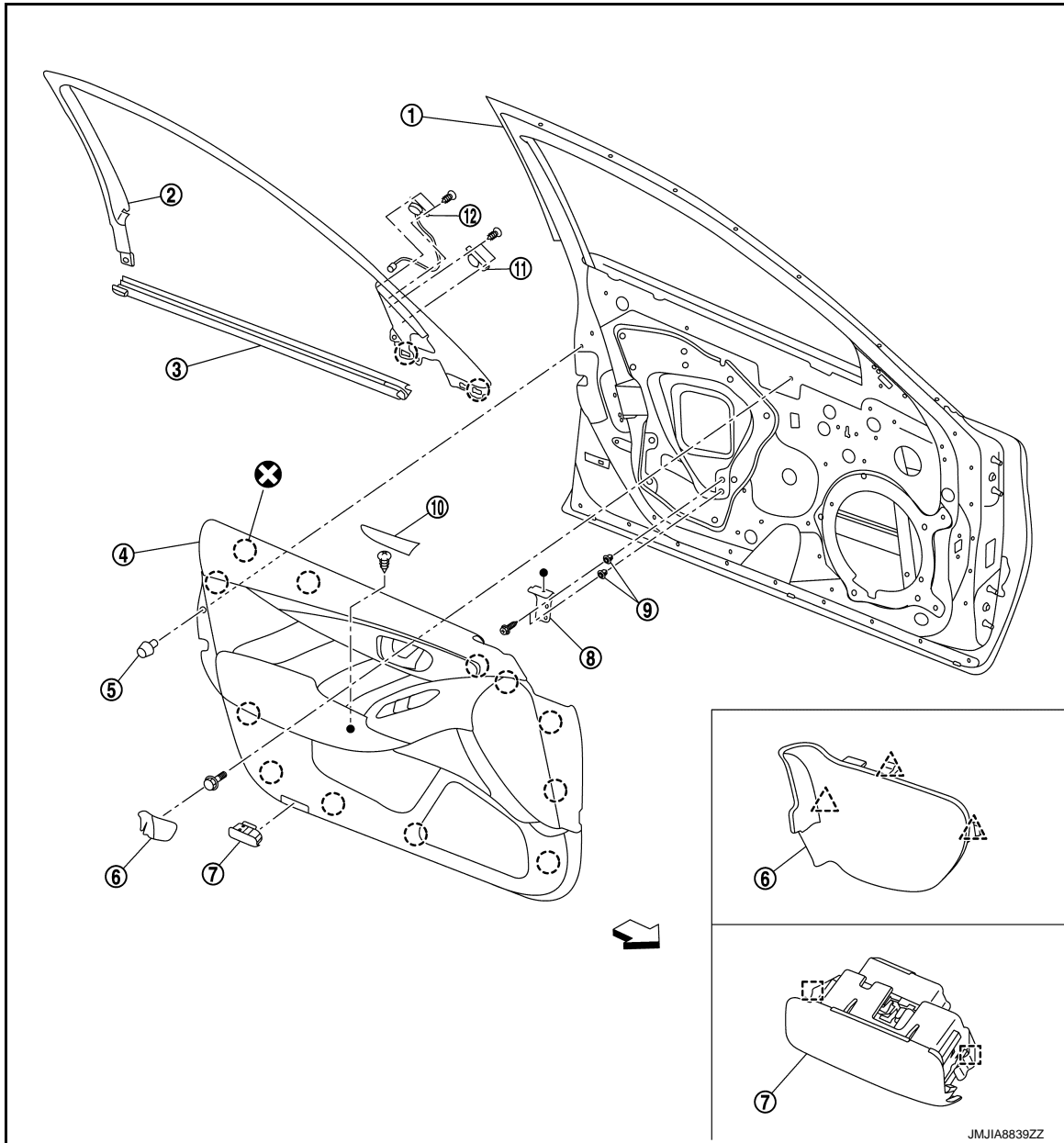

- |                       |                               |   |
|-----------------------|-------------------------------|---|
| ① Front door panel    | ② Front door sash inner cover | ③ Front door inside seal                                |
| ④ Front door finisher | ⑤ Bumper rubber               | ⑥ Inside handle escutcheon                              |
| ⑦ Step lamp           | ⑧ Pull handle bracket         | ⑨ Grommet   |
| ⑩ Pull handle cap     | ⑪ Tweeter*                    | ⑫ Blind Spot Warning/Blind Spot Intervention indicator* |

- : Clip
- △ : Pawl
- : Metal clip
- ⇐ : Vehicle front

# FRONT DOOR FINISHER

## < REMOVAL AND INSTALLATION >

⊗ : Always replace after every disassembly.

●: indicates that the part is connected at points with same symbol in actual vehicle.

\*: This part may not be equipped on some vehicles depending on vehicle specifications.

## FRONT DOOR FINISHER

### FRONT DOOR FINISHER : Removal and Installation

INFOID:0000000011281425

#### CAUTION:

- When removing, always use a remover tool that is made of plastic to prevent damage to the parts.
- Never damage the front door panel.

#### REMOVAL

1. Fully open front door and front door glass.
2. Remove inside handle escutcheon.
  - a. Apply protective tapes (A) on inside handle to protect it from damage.

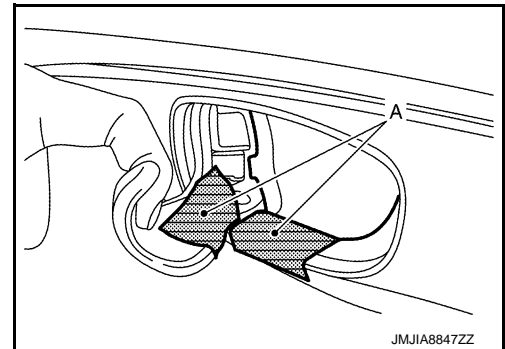

- b. Disengage inside handle escutcheon fixing pawls using a remover tool (A), and then remove inside handle escutcheon.

△ : Pawl

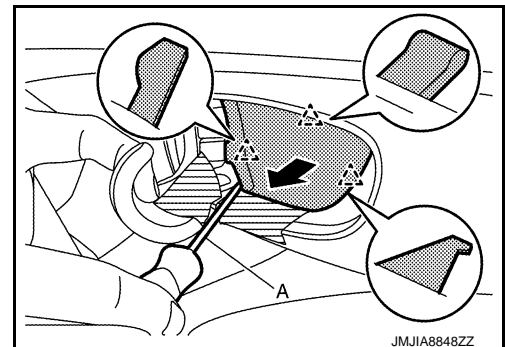

3. Remove front door finisher mounting bolt (A).

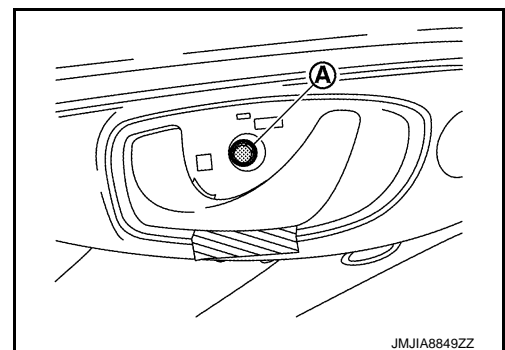

4. Remove pull handle cap.

A  
B  
C  
D  
E  
F  
G  
H  
I  
INT  
K  
L  
M  
N  
O  
P

## FRONT DOOR FINISHER

### < REMOVAL AND INSTALLATION >

- a. Apply protective tape (A) on front door finisher to protect it from damage.

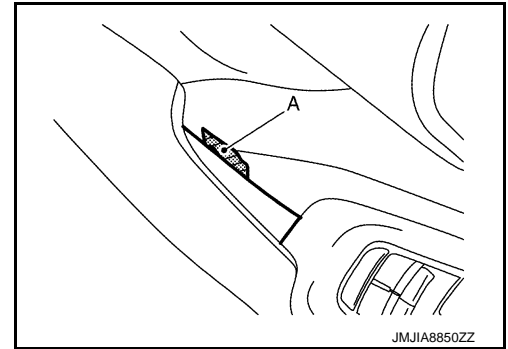

- b. Remove pull handle cap using a remover tool (A).

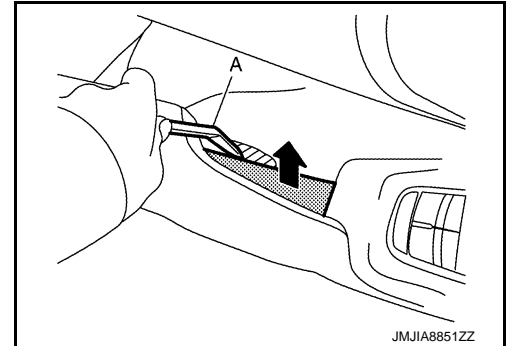

5. Remove front door finisher fixing screw (A).

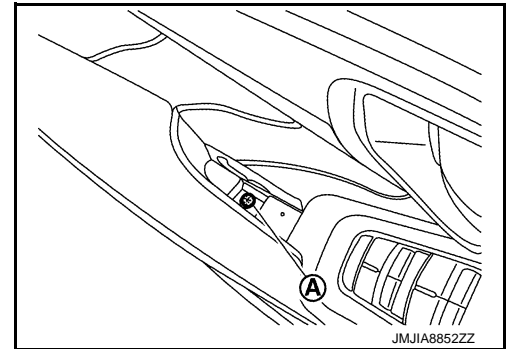

6. Remove bumper rubber according to numerical order 1→2 indicated by arrows as shown in the figure.

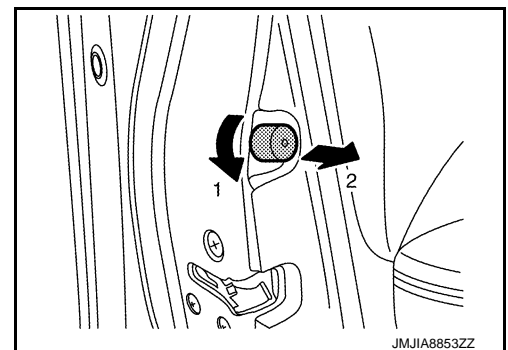

7. Remove step lamp. Refer to [INL-71, "Removal and Installation"](#).

# FRONT DOOR FINISHER

## < REMOVAL AND INSTALLATION >

8. Apply protective tape (A) on front door panel to protect from damage.

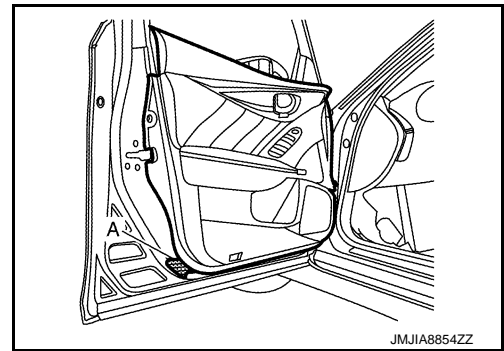

9. Disengage front door finisher fixing clips using a remover tool (A), according to numerical order 1→2 indicated by arrows as shown in the figure.

**CAUTION:**

**Insert a remover tool between front door panel and disengage fixing clips.**

 : Clip

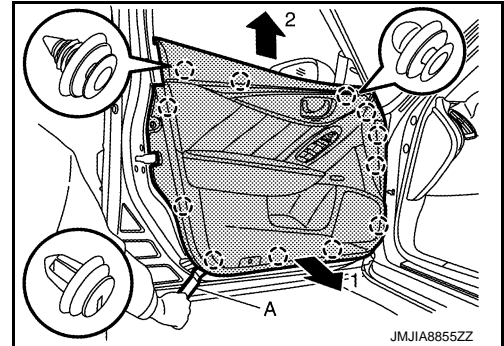

10. Disconnect inside handle cable ① and lock knob cable ② from inside handle ③ according to numerical order 1→4 indicated by arrows as shown in the figure.

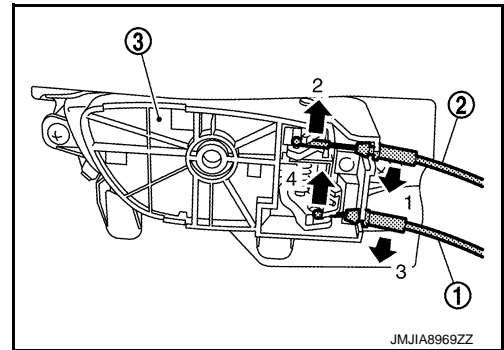

11. Disconnect each harness connectors.
- Seat memory switch harness connector (A) (with seat memory switch).
  - Door mirror remote control switch harness connector (B).
  - Front door squawker harness connector (C) (with front door squawker).
  - Power window main switch harness connector (D).

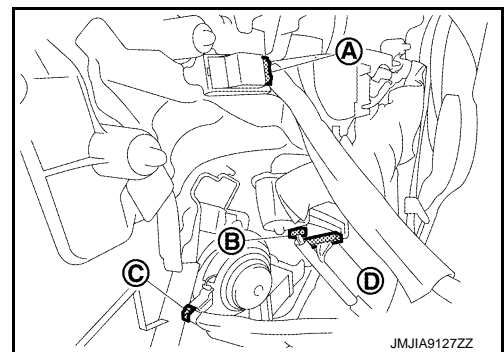

12. Remove front door finisher.
13. Remove parts as per the following list after removing front door finisher.
- Front door inside handle. Refer to [DLK-224, "INSIDE HANDLE : Removal and Installation"](#).
  - Seat memory switch. Refer to [ADP-147, "Removal and Installation"](#) (if equipped).
  - Power window main switch. Refer to [PWC-78, "Removal and Installation"](#).
  - Front door squawker. Refer to [AV-280, "Removal and Installation"](#) (if equipped).

## INSTALLATION

Note the following items, and then install in the reverse order of removal.

**CAUTION:**

- **Visually check clips for deformation and damage during installation. Replace with new ones if necessary.**

A  
B  
C  
D  
E  
F  
G  
H  
I  
INT  
K  
L  
M  
N  
O  
P

# FRONT DOOR FINISHER

## < REMOVAL AND INSTALLATION >

- When installing, check in advance that clips are accurately aligned with the portions on front door panel, and then install by pressing in.
- If power window main switch is replaced or is removed, it is necessary to perform the initialization procedure. Refer to [PWC-38, "Work Procedure"](#).

## FRONT DOOR SASH INNER COVER

### FRONT DOOR SASH INNER COVER : Removal and Installation

INFOID:000000011281426

#### CAUTION:

- When removing, always use a remover tool that is made of plastic to prevent damage to the parts.
- Never damage the door panel.

#### REMOVAL

1. Remove front door finisher. Refer to [INT-13, "FRONT DOOR FINISHER : Removal and Installation"](#).
2. Remove front door inside seal.

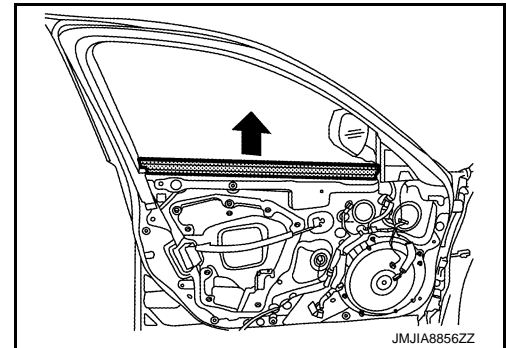

3. Disconnect Blind Spot Warning/Blind Spot Intervention indicator harness connector (A) (with Blind Spot Warning/Blind Spot Intervention indicator).

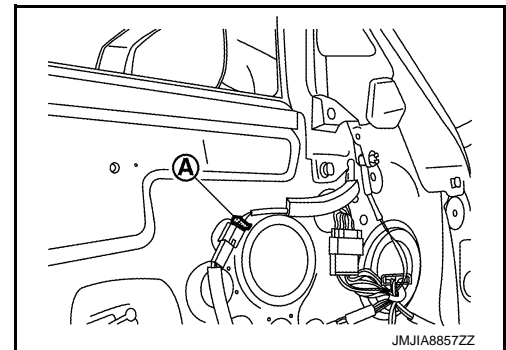

4. Disengage front door sash inner cover fixing clips using a remover tool (A).

 : Clip

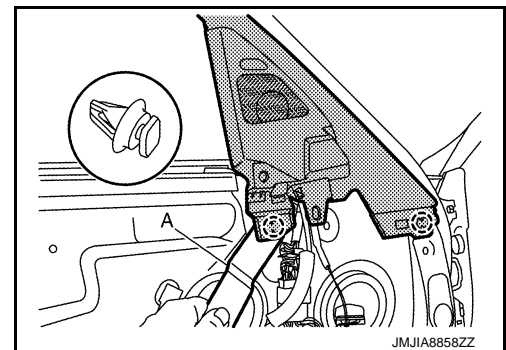



# FRONT DOOR FINISHER

## < REMOVAL AND INSTALLATION >

5. Remove front door sash inner cover according to numerical order 1→3 indicated by arrows as shown in the figure.

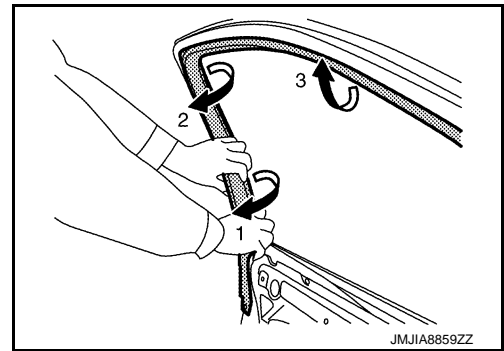

6. Disconnect tweeter harness connector (A) (with tweeter).

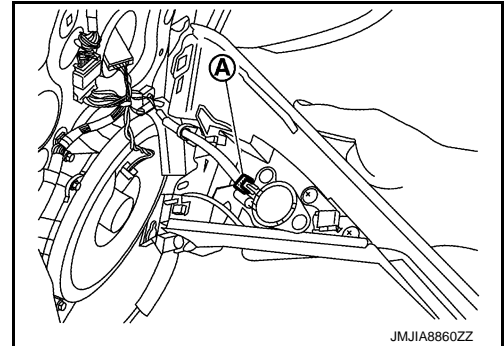

7. Remove following parts after removing front door sash inner cover.
- Tweeter. Refer to [AV-279. "Removal and Installation"](#) (if equipped).
  - Blind Spot Warning/Blind Spot Intervention indicator. Refer to [DAS-389. "Removal and Installation"](#) (if equipped).

## INSTALLATION

Note the following items, and then install in the reverse order of removal.

### CAUTION:

- Visually check clips for deformation and damage during installation. Replace with new ones if necessary.
- When installing, check in advance that clips are accurately aligned with the portions on front door panel, and then install by pressing in.

A  
B  
C  
D  
E  
F  
G  
H  
I  
INT  
K  
L  
M  
N  
O  
P

# REAR DOOR FINISHER

< REMOVAL AND INSTALLATION >

## REAR DOOR FINISHER

Exploded View

INFOID:000000011281427

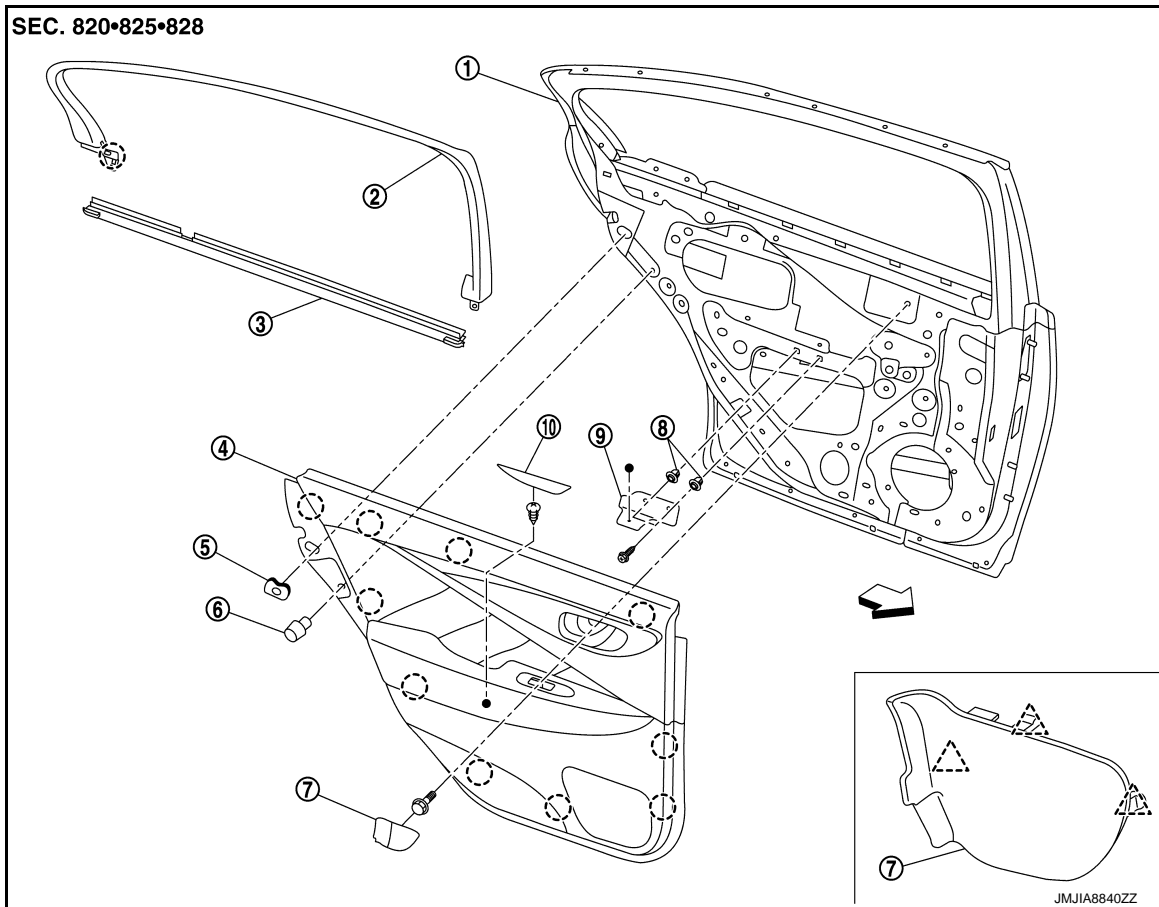

- |                            |                              |                         |
|----------------------------|------------------------------|-------------------------|
| ① Rear door panel          | ② Rear door sash inner cover | ③ Rear door inside seal |
| ④ Rear door finisher       | ⑤ Child lock lever cover     | ⑥ Bumper rubber         |
| ⑦ Inside handle escutcheon | ⑧ Grommet                    | ⑨ Pull handle bracket   |
| ⑩ Pull handle cap          |                              |                         |

○ : Clip

△ : Pawl

⇐ : Vehicle front

● : Indicates that the part is connected at points with same symbol in actual vehicle.

## REAR DOOR FINISHER

### REAR DOOR FINISHER : Removal and Installation

INFOID:000000011281428

#### CAUTION:

- When removing, always use a remover tool that is made of plastic to prevent damage to the parts.
- Never damage the rear door panel.

#### REMOVAL

1. Fully open rear door and rear door glass.
2. Remove inside handle escutcheon.

# REAR DOOR FINISHER

## < REMOVAL AND INSTALLATION >

- a. Apply protective tapes (A) on inside handle to protect it from damage.

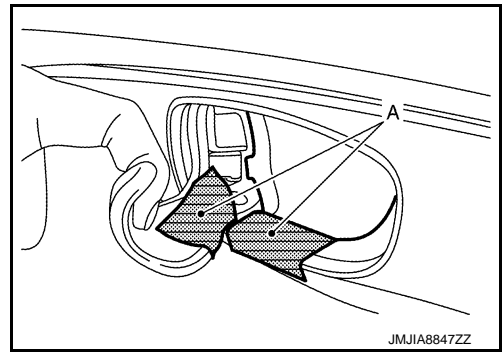

- b. Disengage inside handle escutcheon fixing pawls using a remover tool (A), and then remove inside handle escutcheon.

 : Pawl

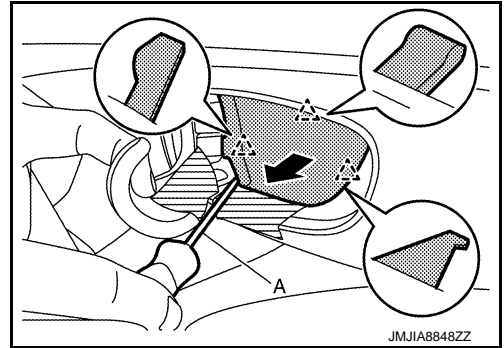

3. Remove rear door finisher mounting bolt (A).

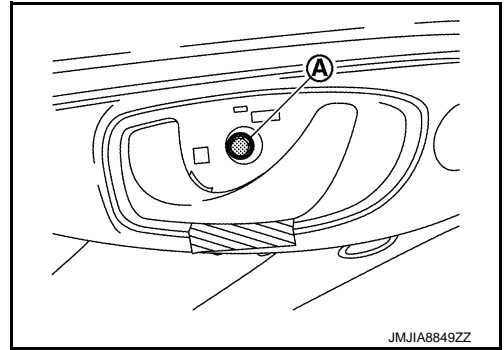

4. Apply protective tape (A) on rear door finisher to protect it from damage.

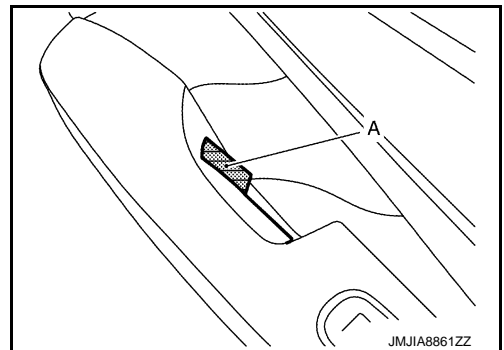

5. Remove pull handle cap using a remover tool (A).

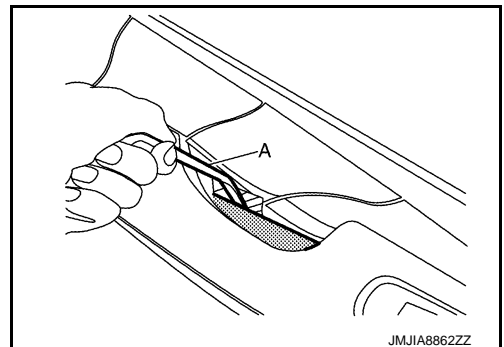

A  
B  
C  
D  
E  
F  
G  
H  
I  
INT  
K  
L  
M  
N  
O  
P

# REAR DOOR FINISHER

## < REMOVAL AND INSTALLATION >

6. Remove rear door finisher fixing screw (A).

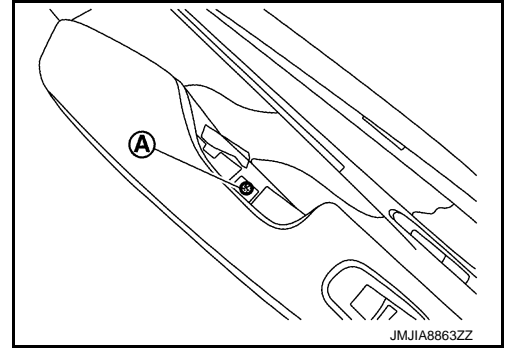

7. Remove bumper rubber according to numerical order 1→2 indicated by arrows as shown in the figure.

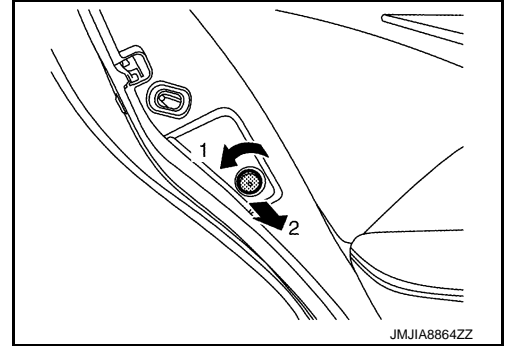

8. Remove child lock lever cover.

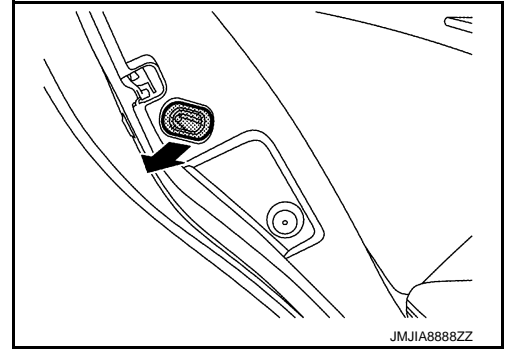

9. Apply protective tape (A) on rear door panel to protect it from damage.

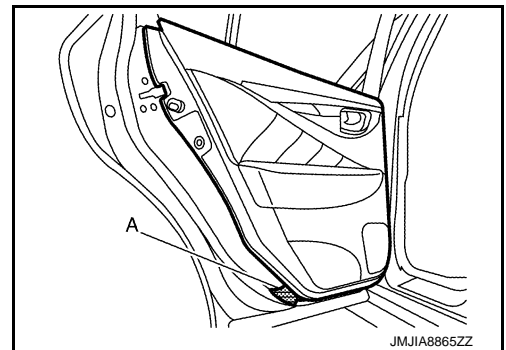

10. Disengage rear door finisher fixing clips using a remover tool (A) according to numerical order 1→2 indicated by arrows as shown in the figure.

**CAUTION:**

Insert a remover tool between the rear door finisher and rear door panel to disengage the fixing clips.

 : Clip

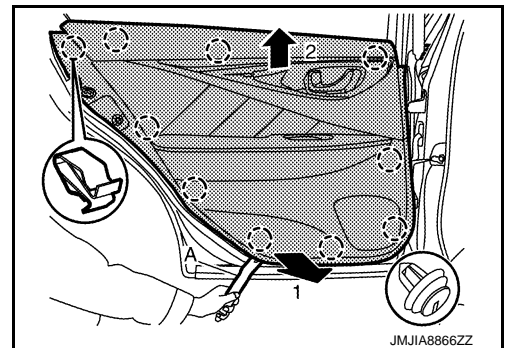

# REAR DOOR FINISHER

## < REMOVAL AND INSTALLATION >

11. Disconnect inside handle cable ① and lock knob cable ② from inside handle ③ according to numerical order 1→4 indicated by arrows as shown in the figure.

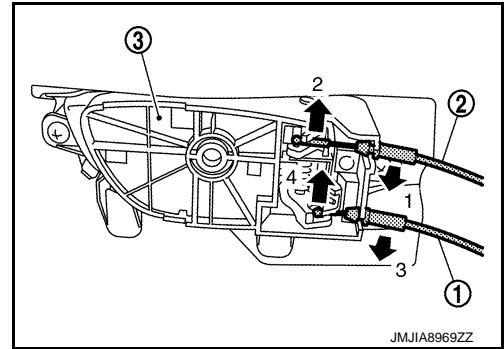

12. Disconnect rear power window switch harness connector (A), and then remove rear door finisher.

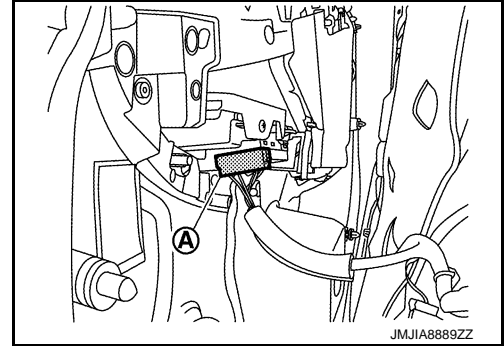

13. Remove following parts after removing rear door finisher.
- Inside handle. Refer to [DLK-229. "INSIDE HANDLE : Removal and Installation"](#).
  - Rear power window switch. Refer to [PWC-79. "Removal and Installation"](#).

## INSTALLATION

Note the following items, and then install in the reverse order of removal.

### CAUTION:

- Visually check clips for deformation and damage during installation. Replace with new ones if necessary.
- When installing, check in advance that clips are accurately aligned with the portions on rear door panel, and then install by pressing in.

## REAR DOOR SASH INNER COVER

### REAR DOOR SASH INNER COVER : Removal and Installation

INFOID:000000011281429

### CAUTION:

- When removing, always use a remover tool that is made of plastic to prevent damage to the parts.
- Never damage the door panel.

## REMOVAL

1. Remove rear door finisher. Refer to [INT-13. "FRONT DOOR FINISHER : Removal and Installation"](#).
2. Remove rear door inside seal.

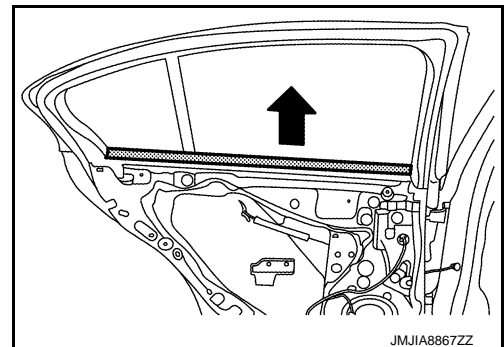

# REAR DOOR FINISHER

## < REMOVAL AND INSTALLATION >

3. Disengage rear door sash inner cover fixing clip using a remover tool (A).

 : Clip

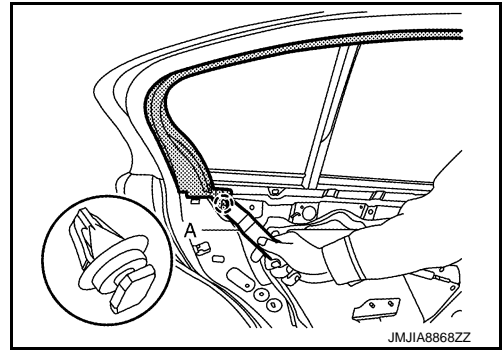

4. Remove rear door sash inner cover according to numerical order 1→3 indicated by arrows as shown in the figure.

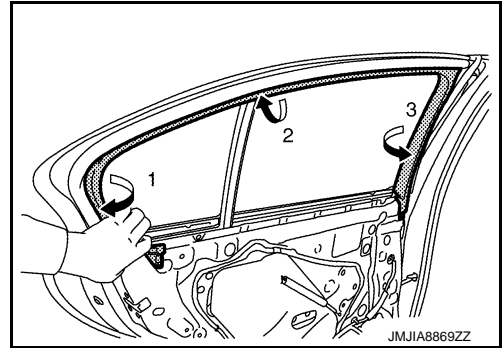

## INSTALLATION

Note the following items, and then install in the reverse order of removal.

### **CAUTION:**

- Visually check clip for deformation and damage during installation. Replace with new ones if necessary.
- When installing, check in advance that clip is accurately aligned with the portions on rear door panel, and then install by pressing in.

# BODY SIDE TRIM

< REMOVAL AND INSTALLATION >

## BODY SIDE TRIM

Exploded View

INFOID:000000011281430

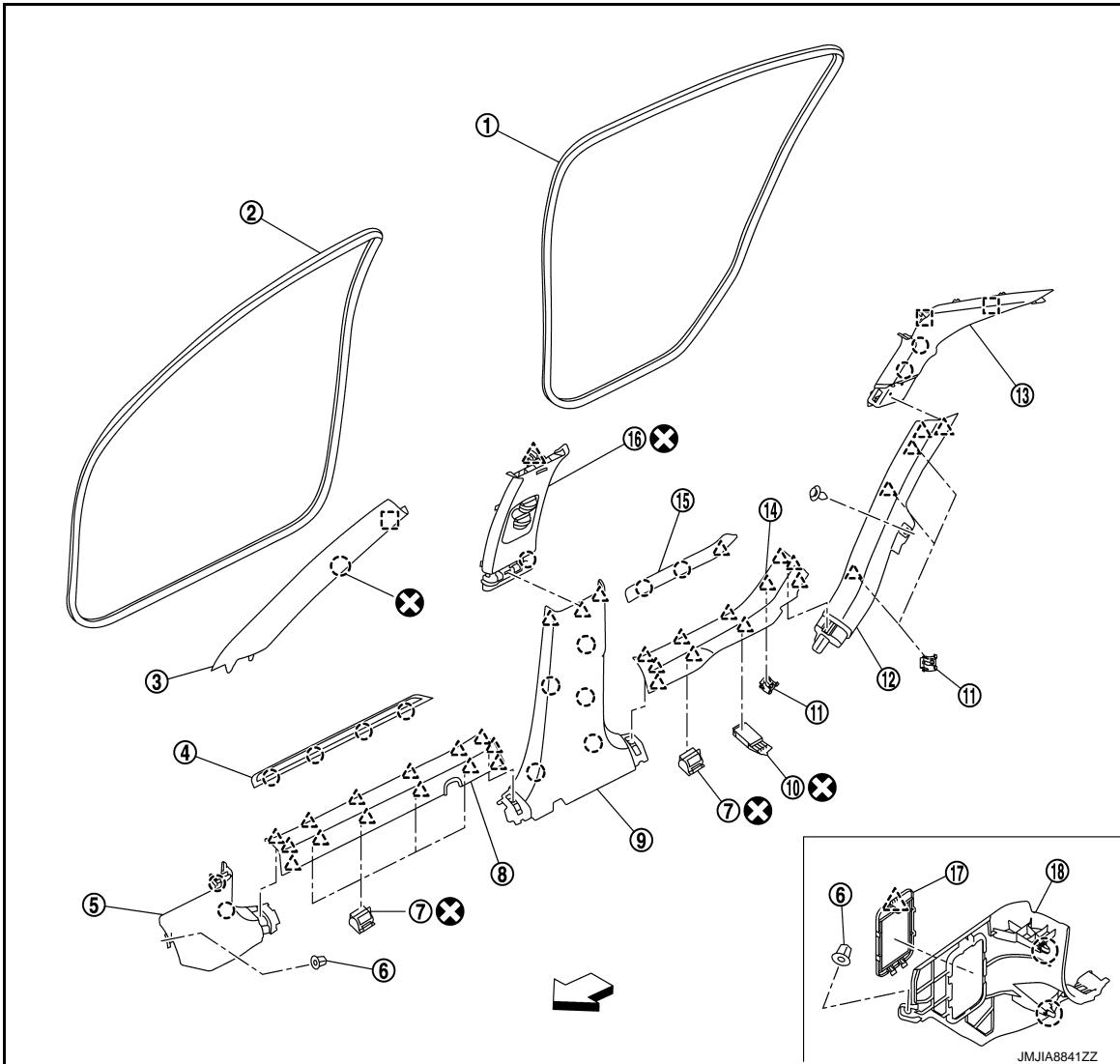

- |                               |                             |                               |
|-------------------------------|-----------------------------|-------------------------------|
| ① Rear body side welt         | ② Front body side welt      | ③ Front pillar garnish        |
| ④ Front kicking plate outer   | ⑤ Dash side finisher RH     | ⑥ Dash clip                   |
| ⑦ Harness clip                | ⑧ Front kicking plate inner | ⑨ Center pillar lower garnish |
| ⑩ Harness clip                | ⑪ Metal clip                | ⑫ Rear wheel house garnish    |
| ⑬ Rear pillar finisher        | ⑭ Rear kicking plate inner  | ⑮ Rear kicking plate outer    |
| ⑯ Center pillar upper garnish | ⑰ Fuse lid                  | ⑱ Dash side finisher LH       |

○ : Clip

△ : Pawl

□ : Metal clip

⊗ : Always replace after every disassembly.

↔ : Vehicle front

## FRONT PILLAR GARNISH

A  
B  
C  
D  
E  
F  
G  
H  
I  
INT  
K  
L  
M  
N  
O  
P

# BODY SIDE TRIM

< REMOVAL AND INSTALLATION >

## FRONT PILLAR GARNISH : Removal and Installation

INFOID:000000011281431

### CAUTION:

Never damage the body panel.

### REMOVAL

1. Release front pillar garnish portion of front body side welt.
2. Disengage front pillar garnish fixing metal clip and anchor clip.

 : Anchor clip

 : Metal clip

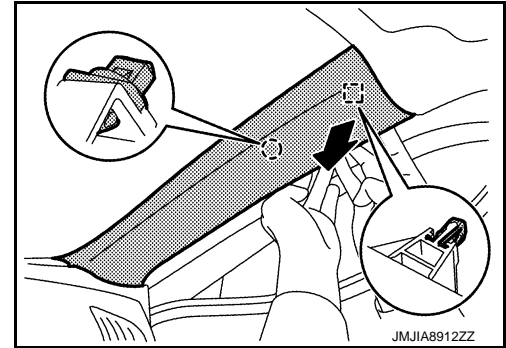

3. Cut anchor clip portion.

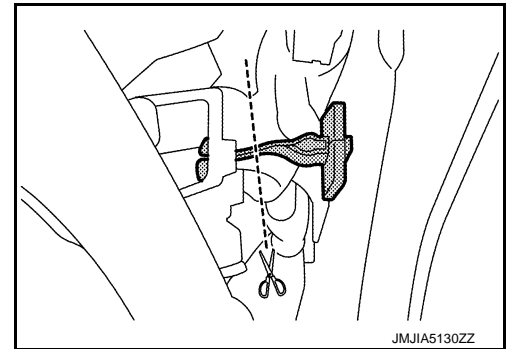

4. Remove front pillar garnish.

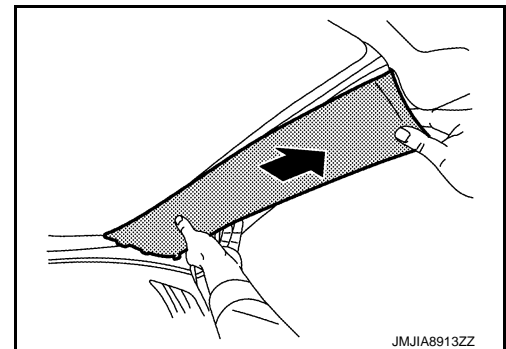

5. Remove anchor clip from body panel.

### INSTALLATION

Note the following items, and then install in the reverse order of removal.

### CAUTION:

- Always replace anchor clips with a new one after every removal.
- Be sure to install anchor clip to front pillar garnish before installing front pillar garnish.
- Visually check metal clip for deformation and damage during installation. Replace with new one if necessary.
- When installing, check in advance that anchor clip and metal clip are accurately aligned with the portions on body panel, and then install by pressing in.

## KICKING PLATE OUTER



# BODY SIDE TRIM

## < REMOVAL AND INSTALLATION >

### KICKING PLATE OUTER : Removal and Installation

INFOID:000000011281432

#### CAUTION:

- When removing, always use a remover tool that is made of plastic to prevent damage to the parts.
- Never damage the body panel.

#### REMOVAL

##### Front

1. Apply protective tape (A) on body panel to protect it from damage.

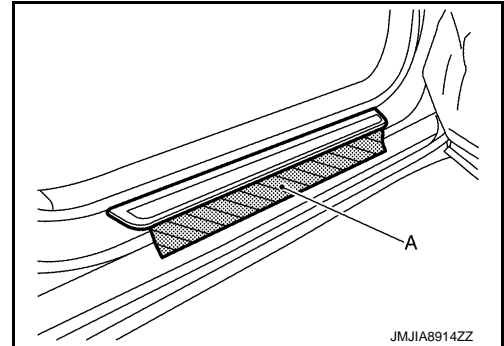

2. Disengage front kicking plate outer fixing clips using a remover tool (A), and then remove front kicking plate outer.

○ : Clip

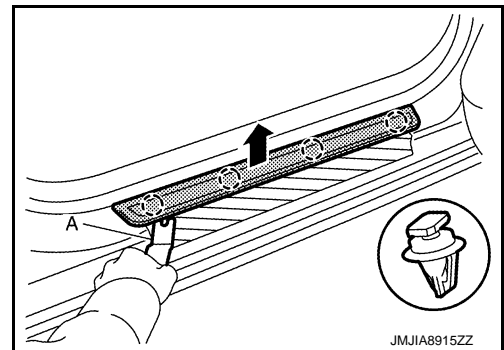

##### Rear

1. Apply protective tape (A) on body panel to protect it from damage.

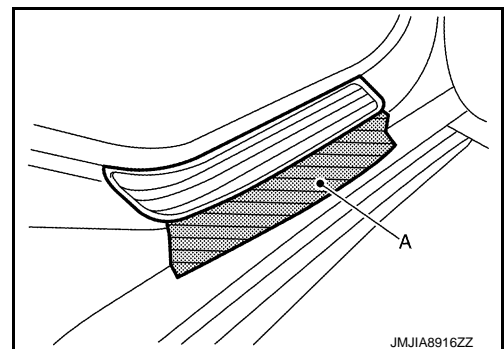

2. Disengage rear kicking plate outer fixing pawl and clips using a remover tool (A), and then remove rear kicking plate outer.

○ : Clip

△ : Pawl

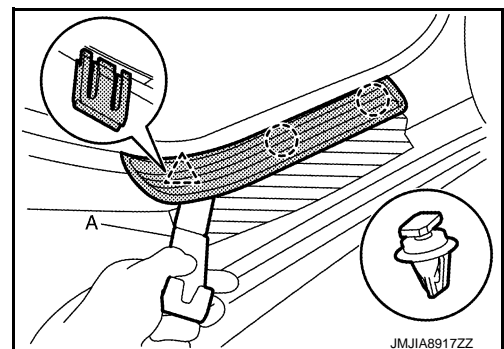

#### INSTALLATION

Note the following items, and then install in the reverse order of removal.

A  
B  
C  
D  
E  
F  
G  
H  
I  
INT  
K  
L  
M  
N  
O  
P

# BODY SIDE TRIM

## < REMOVAL AND INSTALLATION >

### CAUTION:

- Visually check clips for deformation and damage during installation. Replace with new ones if necessary.
- When installing, check in advance that clips and pawl are accurately aligned with the portions on the body panel, and then install by pressing in.

## KICKING PLATE INNER

### KICKING PLATE INNER : Removal and Installation

INFOID:000000011281433

### CAUTION:

Never damage the body panel.

## REMOVAL

Front

1. Move front seat to the frontmost position.
2. Disengage front kicking plate inner fixing pawls of front end portion indicated by arrow as shown in the figure.

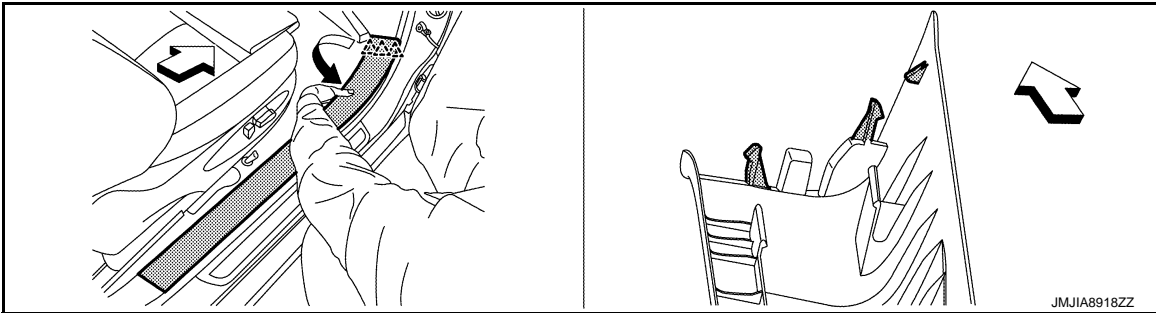

- △ : Pawl  
← : Vehicle front

3. Disengage front kicking plate inner fixing pawls of rear end portion indicated by arrow as shown in the figure.

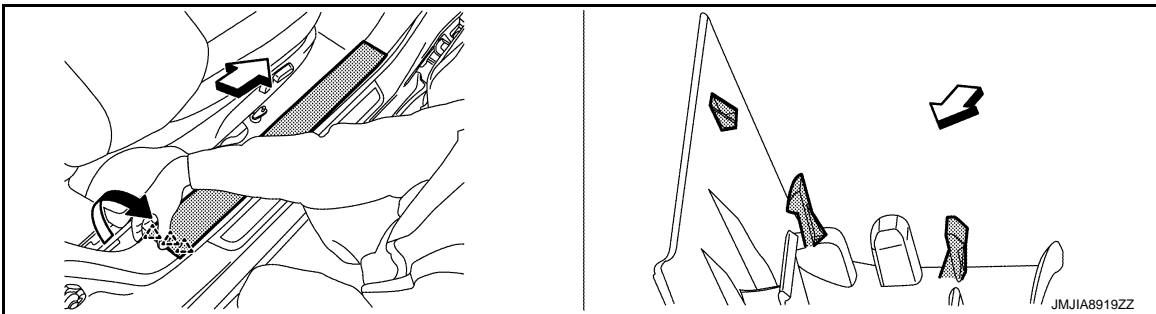

- △ : Pawl  
← : Vehicle front

4. Disengage front kicking plate inner fixing pawls of center portion, and then remove front kicking plate inner.

- △ : Pawl

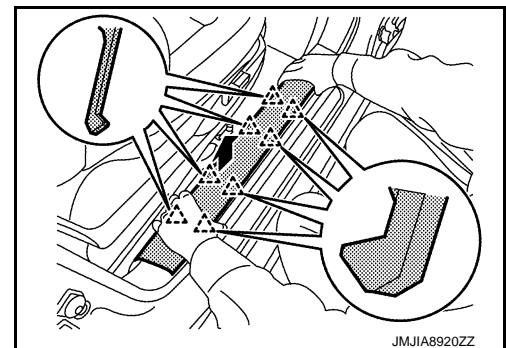

# BODY SIDE TRIM

## < REMOVAL AND INSTALLATION >

### Rear

1. Remove rear seat cushion. Refer to the following.
  - Bench seat models: [SE-97, "SEAT CUSHION : Removal and Installation"](#).
  - 6 : 4 separate seat models: [SE-106, "SEAT CUSHION : Removal and Installation"](#).
2. Disengage rear kicking plate inner fixing pawls of rear end portion indicated by arrow as shown in the figure.

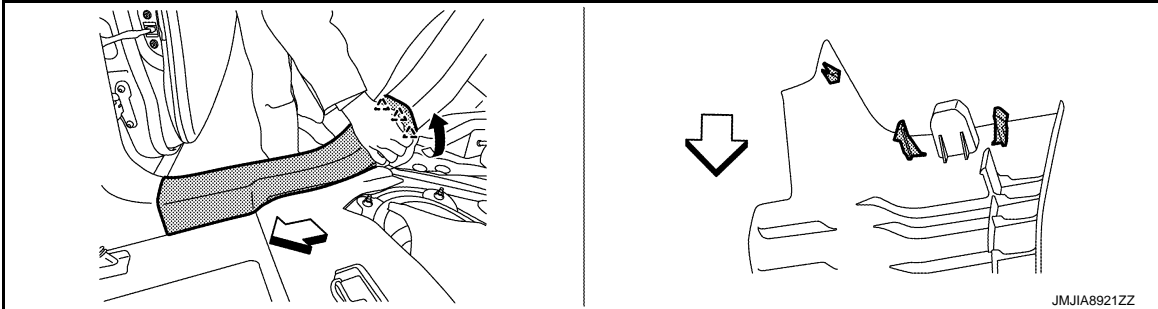

△ : Pawl  
⇐ : Vehicle front

3. Disengage rear kicking plate inner fixing pawls of front end portion indicated by arrow as shown in the figure.

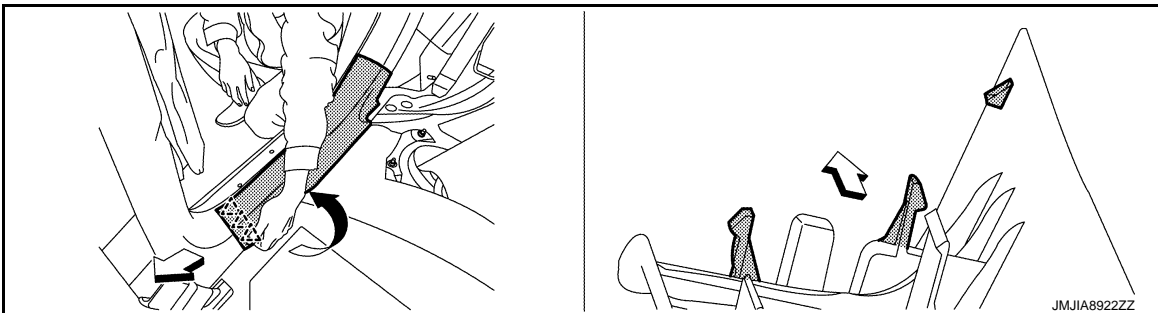

△ : Pawl  
⇐ : Vehicle front

4. Disengage rear kicking plate inner fixing pawls of center portion, and then remove rear kicking plate inner.

△ : Pawl

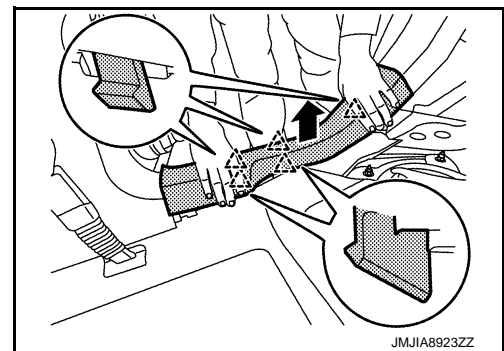

### INSTALLATION

Note the following item, and then install in the reverse order of removal.

#### **CAUTION:**

**When installing, check in advance that pawls are accurately aligned with the portions on dash side finisher and center pillar lower garnish, and then install by pressing in.**

### DASH SIDE FINISHER

# BODY SIDE TRIM

< REMOVAL AND INSTALLATION >

## DASH SIDE FINISHER : Removal and Installation

INFOID:000000011281434

### CAUTION:

Never damage the body.

### REMOVAL

1. Remove front kicking plate inner. Refer to [INT-26, "KICKING PLATE INNER : Removal and Installation"](#).
2. Remove instrument lower cover. Refer to [IP-13, "Removal and Installation"](#).
3. Remove dash clip (A) and disengage dash side finisher fixing clips according to numerical order 1→2 indicated by arrows as shown in the figure, and then remove dash side finisher.

### CAUTION:

Never pull the portion (B) to prevent damage to dash side finisher.

 : Clip

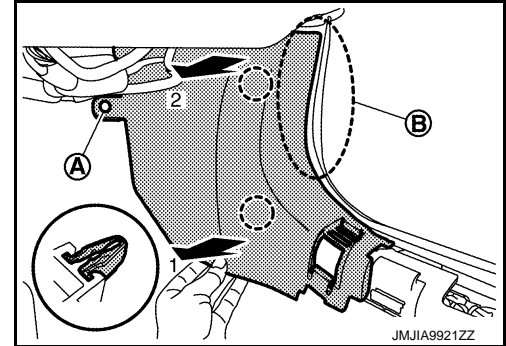

### INSTALLATION

Note the following items, and then install in the reverse order of removal.

### CAUTION:

- Visually check clips for deformation and damage during installation. Replace with new ones if necessary.
- When installing, check in advance that clips are accurately aligned with the portions on body panel, and then install by pressing in.

## BODY SIDE WELT

### BODY SIDE WELT : Removal and Installation

INFOID:000000011281435

### CAUTION:

- Never excessively pull body side welt.
- Never damage the body panel.

### REMOVAL

#### Front

1. Remove dash side finisher. Refer to [INT-28, "DASH SIDE FINISHER : Removal and Installation"](#).
2. Remove center pillar lower garnish. Refer to [INT-28, "CENTER PILLAR LOWER GARNISH : Removal and Installation"](#).
3. Remove front body side welt.

#### Rear

1. Remove rear wheel house garnish. Refer to [INT-30, "REAR WHEEL HOUSE GARNISH : Removal and Installation"](#).
2. Remove center pillar lower garnish. Refer to [INT-28, "CENTER PILLAR LOWER GARNISH : Removal and Installation"](#).
3. Remove rear body side welt.

### INSTALLATION

Install in the reverse order of removal.

## CENTER PILLAR LOWER GARNISH

### CENTER PILLAR LOWER GARNISH : Removal and Installation

INFOID:000000011281436

### CAUTION:

Never damage the body panel.

# BODY SIDE TRIM

## < REMOVAL AND INSTALLATION >

### REMOVAL

1. Fully open front door and rear door.
2. Move front seat to the frontmost position.
3. Remove front kicking plate inner and rear kicking plate inner. Refer to [INT-26. "KICKING PLATE INNER : Removal and Installation"](#).
4. Disengage center pillar lower garnish fixing pawls and clips according to numerical order 1→3 indicated by arrows as shown in the figure, and then remove center pillar lower garnish.

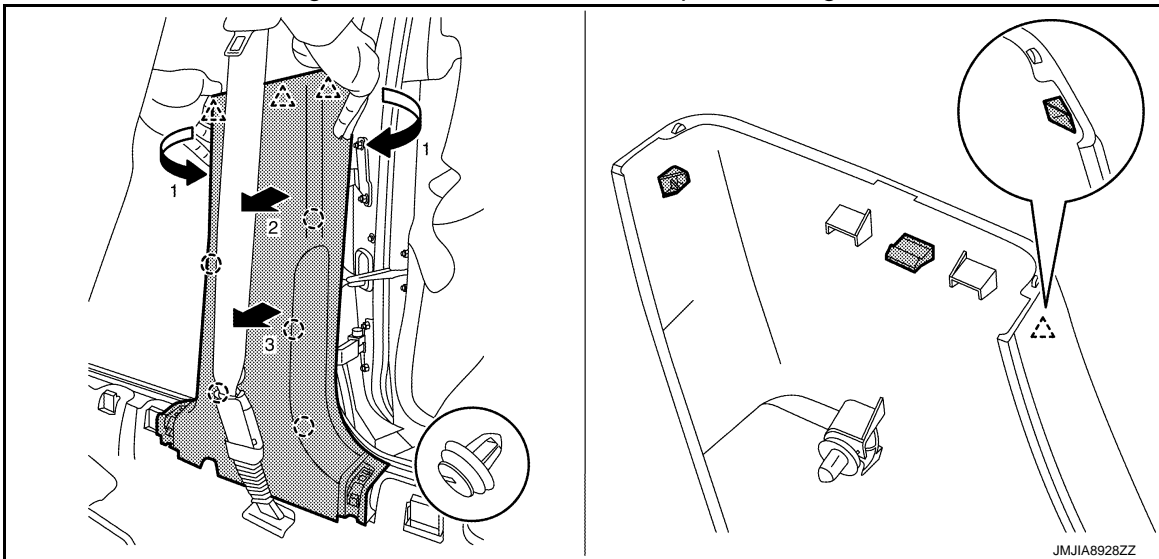

### INSTALLATION

Note the following items, and then install in the reverse order of removal.

#### CAUTION:

- Visually check clips for deformation and damage during installation. Replace with new ones if necessary.
- When installing, check in advance that clips and pawls are accurately aligned with the portions on center pillar upper garnish and body panel, and then install by pressing in.

### CENTER PILLAR UPPER GARNISH

#### CENTER PILLAR UPPER GARNISH : Removal and Installation

INFOID:000000011281437

#### CAUTION:

Never damage the body panel.

### REMOVAL

1. Remove center pillar lower garnish. Refer to [INT-28. "CENTER PILLAR LOWER GARNISH : Removal and Installation"](#).
2. Insert flat-bladed screwdriver (A) into each hole on lap pre-tensioner buckle back side, spread the inner metal portion as shown in the figure, and pull out lap pre-tensioner tongue ① while inserting flat-bladed screwdriver (B) into the hole on lap pre-tensioner buckle.

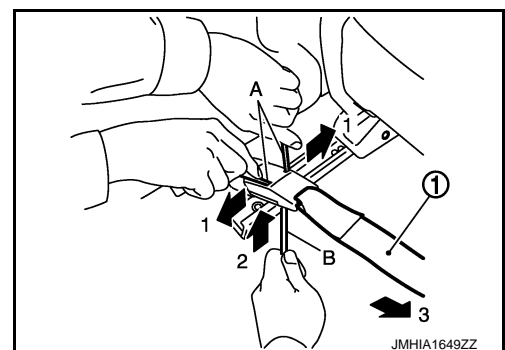

## BODY SIDE TRIM

### < REMOVAL AND INSTALLATION >

- Release front body side welt and rear body side welt of center pillar upper garnish portion.
- Disengage center pillar upper garnish lower side fixing clip.

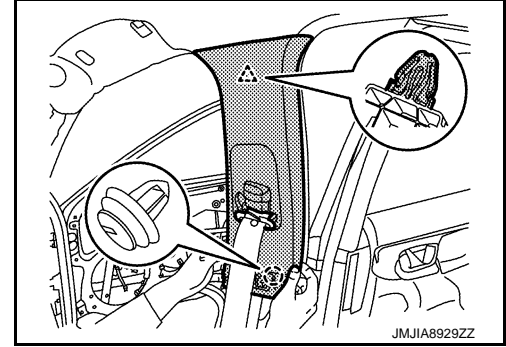
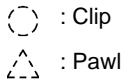

- Disengage center pillar upper garnish upper side fixing pawl, and then remove center pillar upper garnish according to numerical order 1→4 indicated by arrows as shown in the figure.

#### NOTE:

Removal operation can be performed easily when pressing pawls by inserting a remover tool from direction ① as shown in the figure.

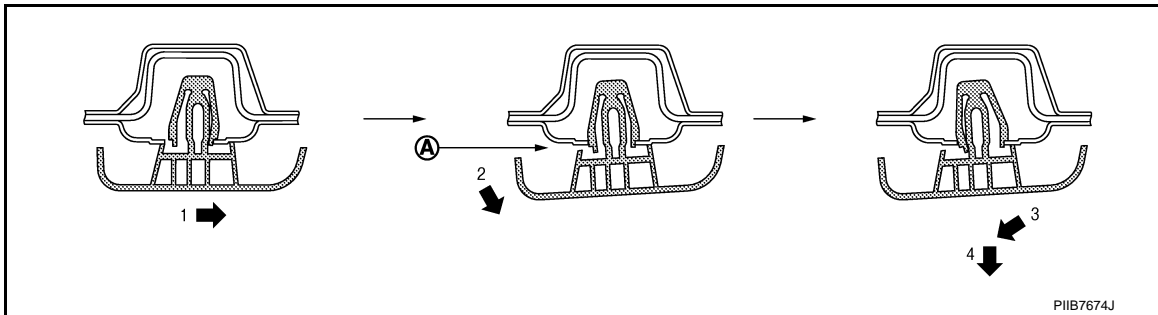

#### CAUTION:

Never apply excessive force when removing center pillar upper garnish. Otherwise, pawl may be damaged and fragments may drop in panel holes on body.

### INSTALLATION

Note the following items, and then install in the reverse order of removal.

#### CAUTION:

- Replace center pillar upper garnish with a new part after removal. Never reuse center pillar upper garnish.
- When installing, check in advance that clip and pawl are accurately aligned with the portions on the body panel, and then install by pressing in.

### REAR WHEEL HOUSE GARNISH

#### REAR WHEEL HOUSE GARNISH : Removal and Installation

INFOID:000000011281438

#### CAUTION:

- When removing, always use a remover tool that is made of plastic to prevent damage to the parts.
- Never damage the body panel.

### REMOVAL

- Remove rear kicking plate inner. Refer to [INT-26, "KICKING PLATE INNER : Removal and Installation"](#).
- Remove the following parts.
  - Rear seatback. Refer to [SE-97, "SEATBACK : Removal and Installation"](#) (Bench seat models).
  - Rear seatback side. Refer to [SE-103, "SEATBACK : Removal and Installation"](#) (6 : 4 separate seat models).

# BODY SIDE TRIM

## < REMOVAL AND INSTALLATION >

3. Remove rear wheel house garnish fixing clip (A).

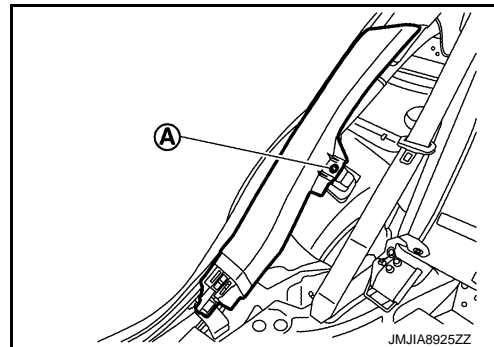

4. Disengage rear wheel house garnish fixing pawls of rear end portion indicated by arrow as shown in the figure.

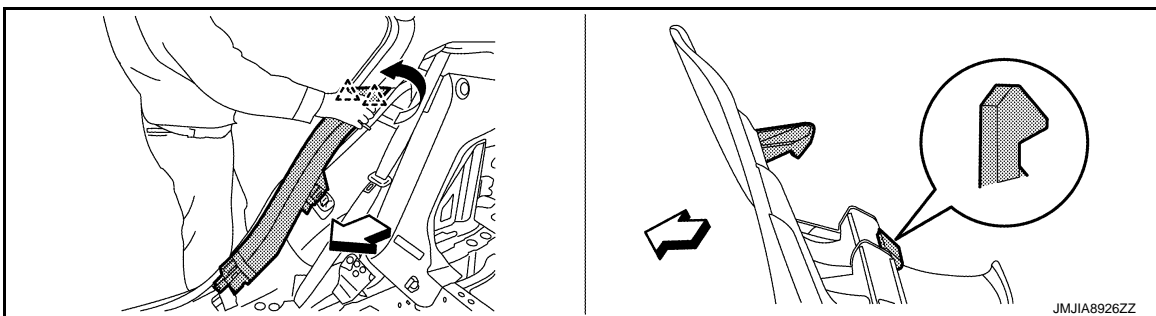

- △ : Pawl  
← : Vehicle front

5. Disengage rear wheel house garnish fixing pawls, and then remove rear wheel house garnish.

- △ : Pawl

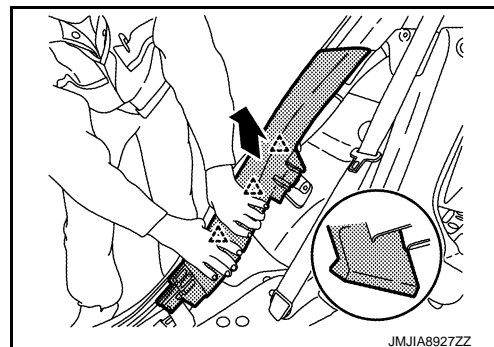

## INSTALLATION

Note the following item, and then install in the reverse order of removal.

### CAUTION:

When installing, check in advance that clip and pawls are accurately aligned with the portions on body panel and rear pillar finisher, and then install by pressing in.

## REAR PILLAR FINISHER

### REAR PILLAR FINISHER : Removal and Installation

INFOID:0000000011281439

### CAUTION:

- When removing, always use a remover tool that is made of plastic to prevent damage to the parts.
- Never damage the body panel.

## REMOVAL

1. Remove rear wheel house garnish. Refer to [INT-30. "REAR WHEEL HOUSE GARNISH : Removal and Installation"](#)
2. Release rear body side welt of rear pillar finisher portion.

## BODY SIDE TRIM

### < REMOVAL AND INSTALLATION >

3. Disengage rear pillar finisher fixing clips using a remover tool (A).

 : Clip

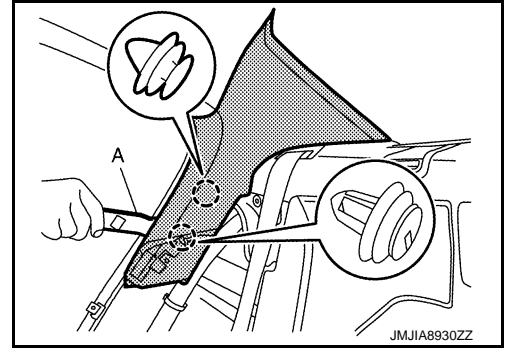

4. Disengage rear pillar finisher fixing metal clips.

 : Metal clip

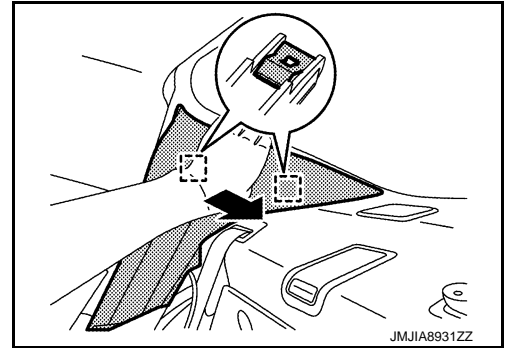

5. Pull rear pillar finisher toward vehicle front, and then remove rear pillar finisher.

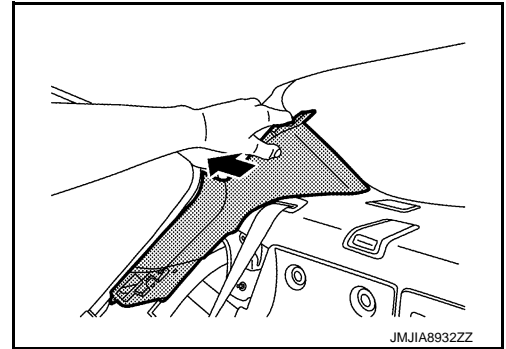

### INSTALLATION

Note the following items, and then install in the reverse order of removal.

#### **CAUTION:**

- Visually check clips and metal clips for deformation and damage during installation. Replace with new ones if necessary.
- When installing, check that fixing portion of rear pillar finisher is engaged to rear parcel shelf finisher.
- When installing, check in advance that clips and metal clips are accurately aligned with the portions on body panel, and then install by pressing in.



# REAR PARCEL SHELF FINISHER

< REMOVAL AND INSTALLATION >

## REAR PARCEL SHELF FINISHER

Exploded View

INFOID:000000011281440

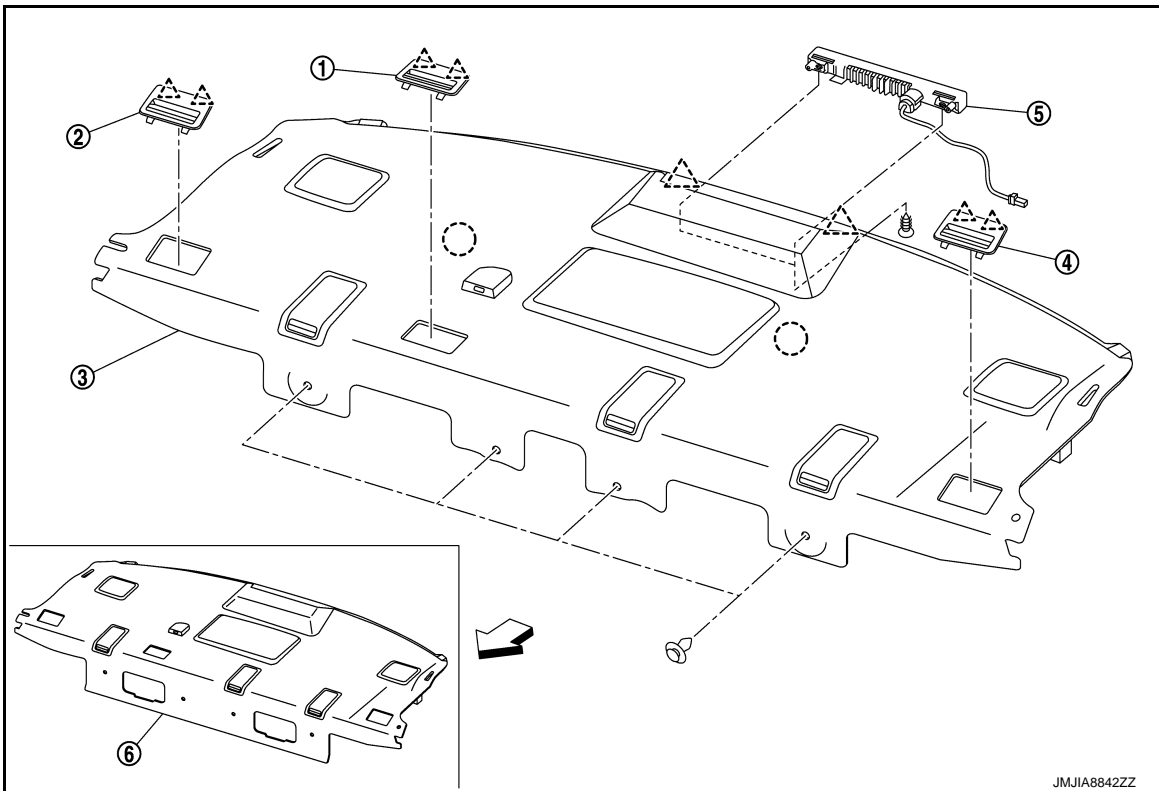

① Seat belt finisher center

② Seat belt finisher RH

③ Rear parcel shelf finisher (bench seat models)

④ Seat belt finisher LH

⑤ High-mounted stop lamp

⑥ Rear parcel shelf finisher (6 : 4 separate seat models)

○ : Clip

△ : pawl

← : Vehicle front

## Removal and Installation

INFOID:000000011281441

### CAUTION:

- When removing, always use a remover tool that is made of plastic to prevent damage to the parts.
- Never damage the body panel.

### REMOVAL

#### Bench Seat Models

1. Remove rear pillar finisher (LH and RH). Refer to [INT-31. "REAR PILLAR FINISHER : Removal and Installation"](#).

## REAR PARCEL SHELF FINISHER

### < REMOVAL AND INSTALLATION >

2. Disengage seat belt finisher fixing pawls using a remover tool (A), and then remove seat belt finisher (LH, RH and center).

 : Pawl

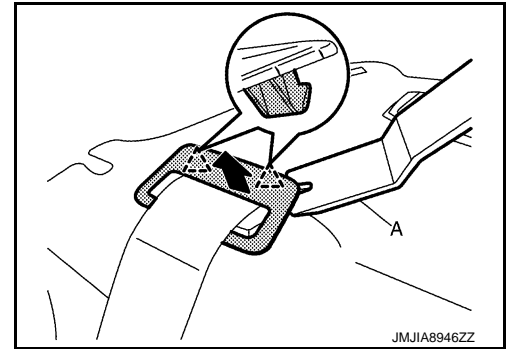

3. Disconnect high-mounted stop lamp harness connector.
  - a. Fully open trunk lid.
  - b. Release trunk lid weather-strip of trunk upper finisher rear end portion ①.
  - c. Remove trunk upper finisher fixing clips (A).
  - d. Pull down trunk upper finisher of rear end portion ②, and then disconnect high-mounted stop lamp harness connector (B).

#### **CAUTION:**

**Never pull down trunk upper finisher by strong force.**

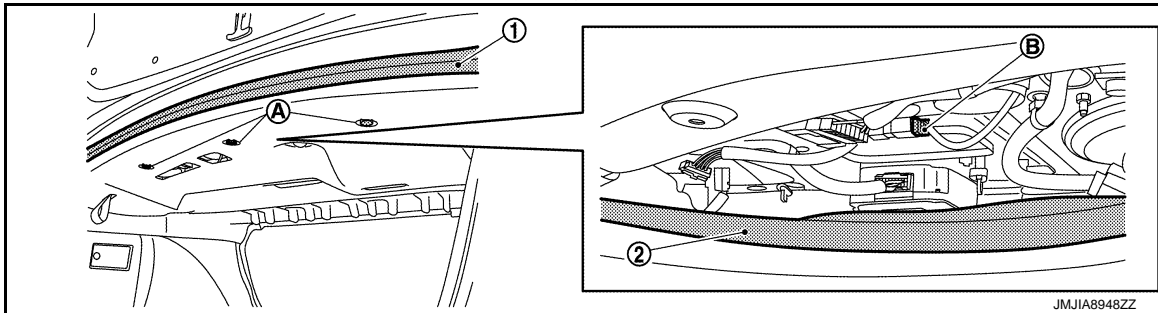

4. Remove rear seatback center finisher. Refer to [INT-50, "REAR SEATBACK FINISHER : Removal and Installation"](#).
5. Remove rear parcel shelf finisher fixing clips (A).

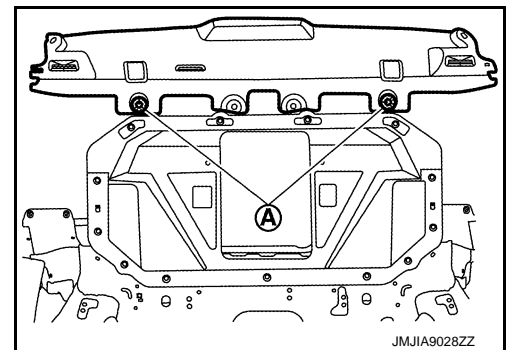

6. Remove mounting anchor bolts of rear seat belt floor anchor (LH, RH and center). Refer to [SB-13, "Exploded View"](#).
7. Pass rear seat belt floor anchor portion (LH, RH and center) through rear parcel shelf finisher.

# REAR PARCEL SHELF FINISHER

## < REMOVAL AND INSTALLATION >

8. Disengage rear parcel shelf finisner fixing clips and pawls, and then remove rear parcel shelf finisner.

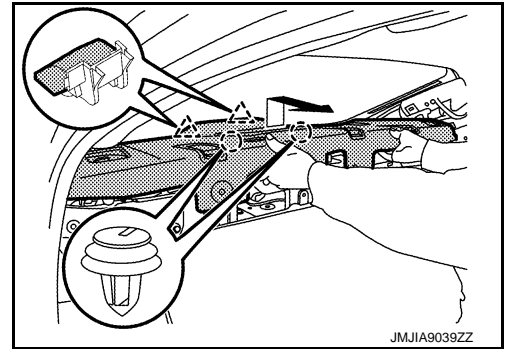
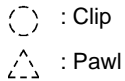

9. Remove high-mounted stop lamp assembly after removing rear parcel shelf finisner. Refer to [EXL-186, "Removal and Installation"](#).

6 : 4 Separate Seat Models

1. Remove rear pillar finisner (LH and RH). Refer to [INT-31, "REAR PILLAR FINISNER : Removal and Installation"](#).
2. Disengage seat belt finisner fixing pawls using a remover tool (A), and then remove seat belt finisner (LH, RH and center).

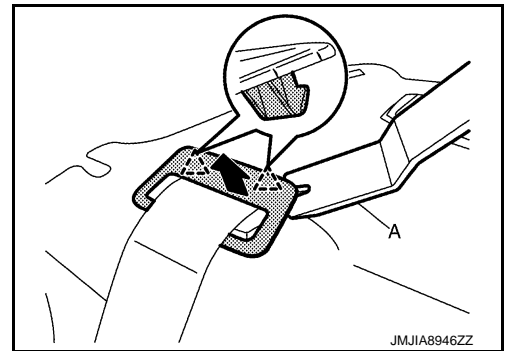
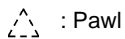

3. Disconnect high-mounted stop lamp harness connector.
- Fully open trunk lid.
  - Release trunk lid weather-strip of trunk upper finisner rear end portion ①.
  - Remove trunk upper finisner fixing clips (A).
  - Pull down trunk upper finisner of rear end portion ②, and then disconnect high-mounted stop lamp harness connector (B).

### CAUTION:

Never pull down trunk upper finisner by strong force.

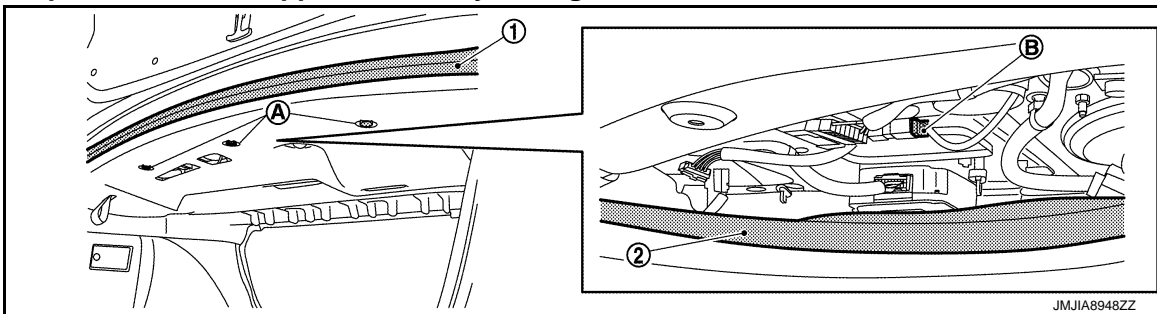

4. Remove rear seat striker cover (LH and RH). Refer to [INT-52, "REAR SEAT STRIKER COVER : Removal and Installation"](#).
5. Remove rear seatback finisner (LH and RH). Refer to [INT-50, "REAR SEATBACK FINISNER : Removal and Installation"](#).

## REAR PARCEL SHELF FINISHER

### < REMOVAL AND INSTALLATION >

6. Remove rear seatback welt.

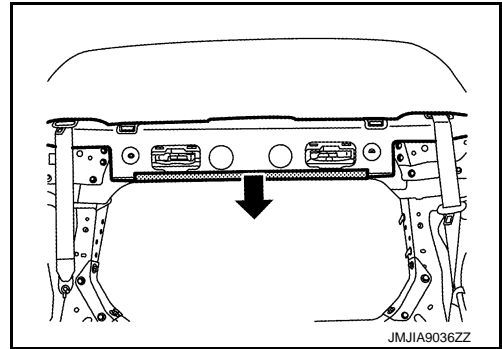

7. Remove rear parcel shelf finisher fixing clips (A).

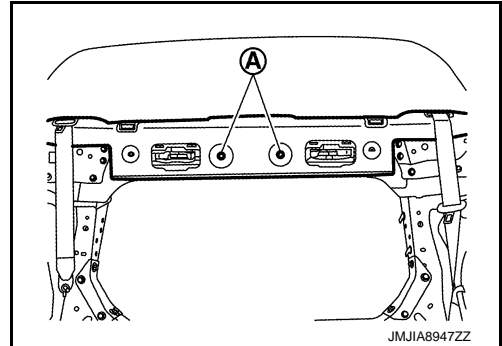

8. Remove mounting anchor bolts of rear seat belt floor anchor (LH and RH). Refer to [SB-13, "Exploded View"](#).
9. Disconnect center seat belt assembly tongue and center seat belt assembly outer.
10. Pass rear seat belt floor anchor portion and center seat belt assembly tongue through rear parcel shelf finisher.
11. Disengage rear parcel shelf finisher fixing clips and pawls, and then remove rear parcel shelf finisher.

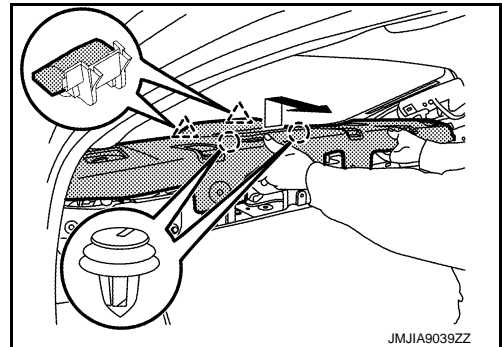
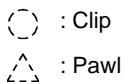

12. Remove high-mounted stop lamp assembly after removing rear parcel shelf finisher. Refer to [EXL-186, "Removal and Installation"](#).

### INSTALLATION

Note the following items, and then install in the reverse order of removal.

#### **CAUTION:**

- Visually check clips for deformation and damage during installation. Replace with new ones if necessary.
- When installing, check in advance that clips and pawls are accurately aligned with the portions on body panel, and then install by pressing in.

# FLOOR TRIM

< REMOVAL AND INSTALLATION >

## FLOOR TRIM

### Exploded View

INFOID:000000011281442

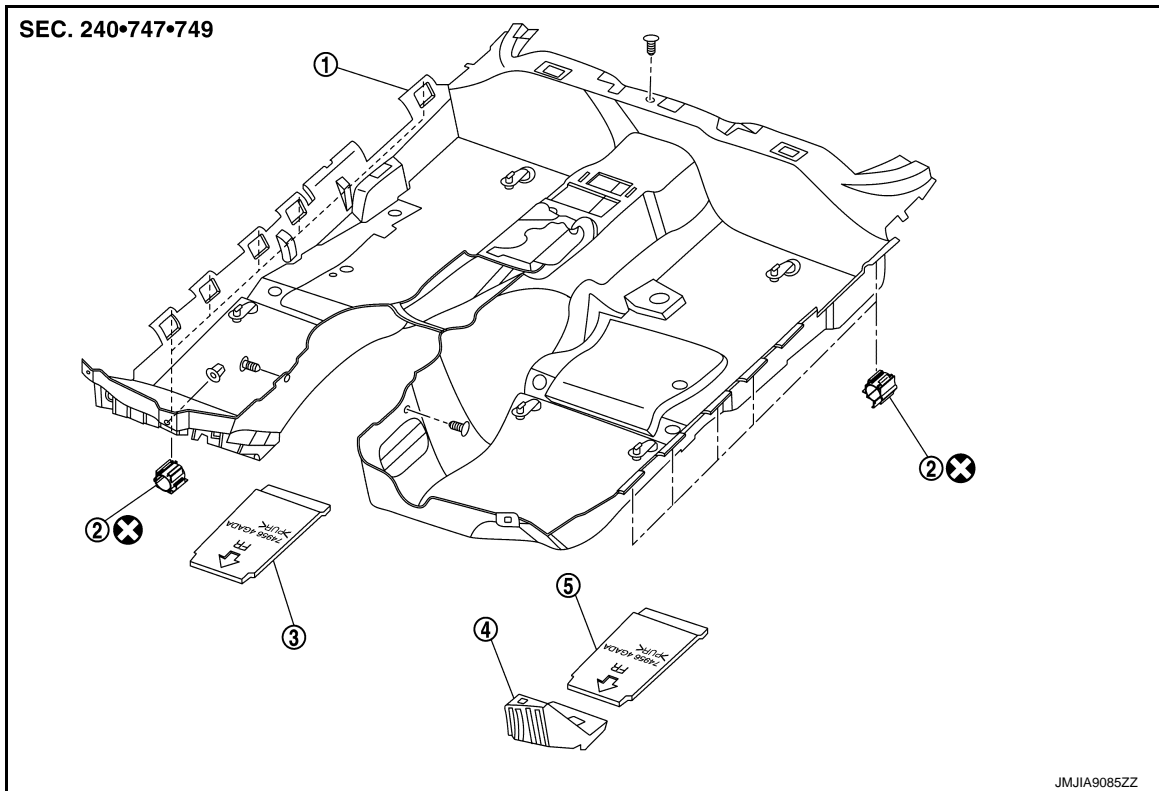

- |                         |                   |                   |
|-------------------------|-------------------|-------------------|
| ① Floor carpet assembly | ② Harness clip    | ③ Floor spacer RH |
| ④ Footrest              | ⑤ Floor spacer LH |                   |
- ⊗ : Always replace after every disassembly.

### Removal and Installation

INFOID:000000011281443

#### CAUTION:

- When removing, always use a remover tool that is made of plastic to prevent damage to the parts.
- Never damage the body.

#### REMOVAL

1. Remove front seat assembly (LH and RH). Refer to [SE-79. "Removal and Installation"](#).
2. Remove rear seat cushion. Refer to the following.
  - Bench seat models: [SE-97. "SEAT CUSHION : Removal and Installation"](#).
  - 6 : 4 separate seat models: [SE-106. "SEAT CUSHION : Removal and Installation"](#).
3. Remove dash side finisher (LH and RH). Refer to [INT-28. "DASH SIDE FINISHER : Removal and Installation"](#).
4. Remove center pillar lower garnish (LH and RH). Refer to [INT-28. "CENTER PILLAR LOWER GARNISH : Removal and Installation"](#).
5. Remove accelerator pedal assembly. Refer to the following.
  - Without distance control assist system: [ACC-3. "MODELS WITHOUT DISTANCE CONTROL ASSIST SYSTEM : Removal and Installation"](#).
  - With distance control assist system: [ACC-4. "MODELS WITH DISTANCE CONTROL ASSIST SYSTEM : Removal and Installation"](#).
6. Remove center console assembly. Refer to [IP-24. "Removal and Installation"](#).

# FLOOR TRIM

## < REMOVAL AND INSTALLATION >

7. Disengage harness clip.

 : Clip

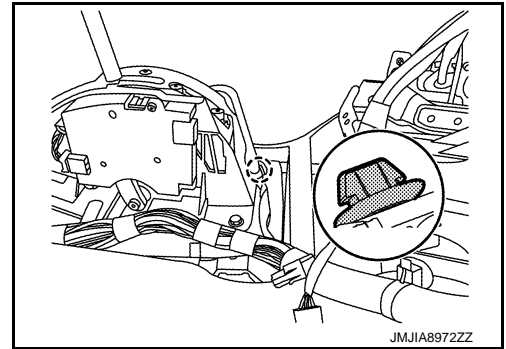

8. Disengage harness clips.

 : Clip

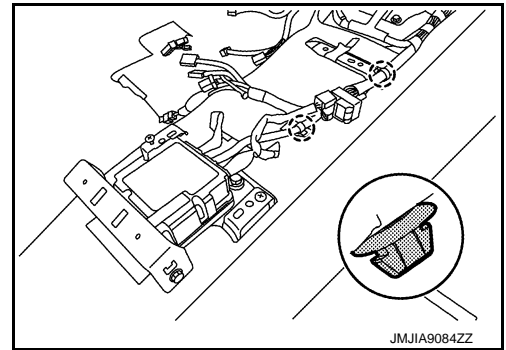

9. Remove center console bracket mounting bolts (A), and then remove center console bracket.

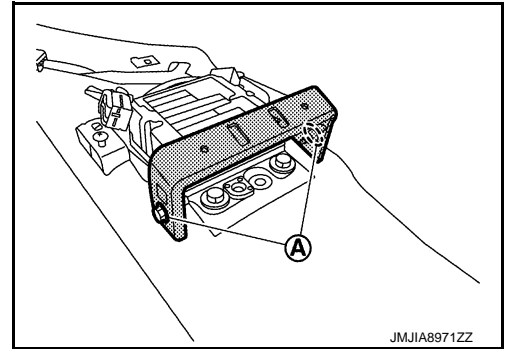

10. Remove diagnosis sensor unit. Refer to [SR-37. "Removal and Installation"](#).

11. Remove floor carpet fixing clips (A) and (B).

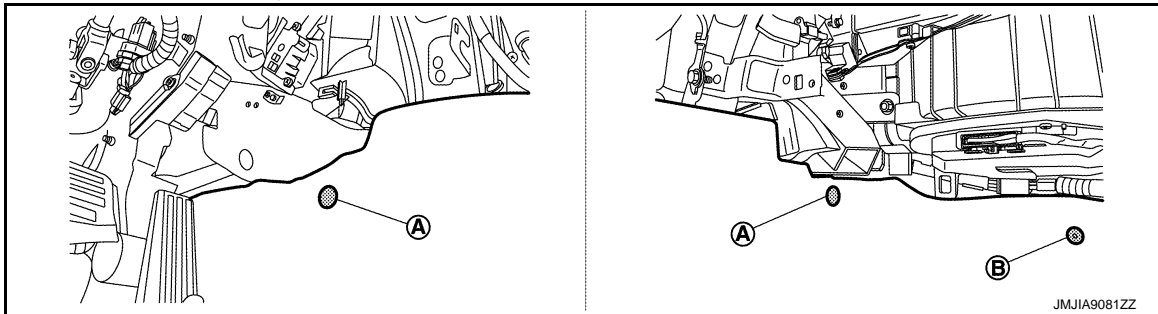

Driver side

Passenger side

## FLOOR TRIM

### < REMOVAL AND INSTALLATION >

12. Remove floor carpet fixing clip (A).

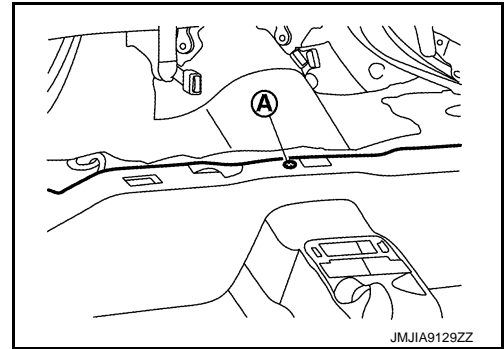

13. Remove floor carpet (1) from floor carpet fixing harness clips (2).

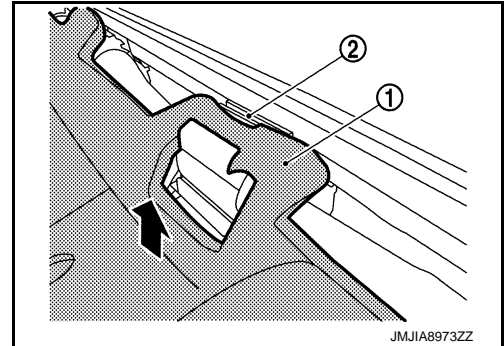

14. Pass each harness through floor carpet opening, toward vehicle floor, so that each harness is free from floor carpet. Remove floor carpet from the vehicle body.

### INSTALLATION

Note the following items, and then install in the reverse order of removal.

#### **CAUTION:**

- Visually check clips for deformation and damage during installation. Replace with new ones if necessary.
- When installing, check in advance that clips are accurately aligned, and then install by pressing in.

A  
B  
C  
D  
E  
F  
G  
H  
I  
INT  
K  
L  
M  
N  
O  
P

# HEADLINING

< REMOVAL AND INSTALLATION >

## HEADLINING

### Exploded View

INFOID:000000011281444

Normal roof models

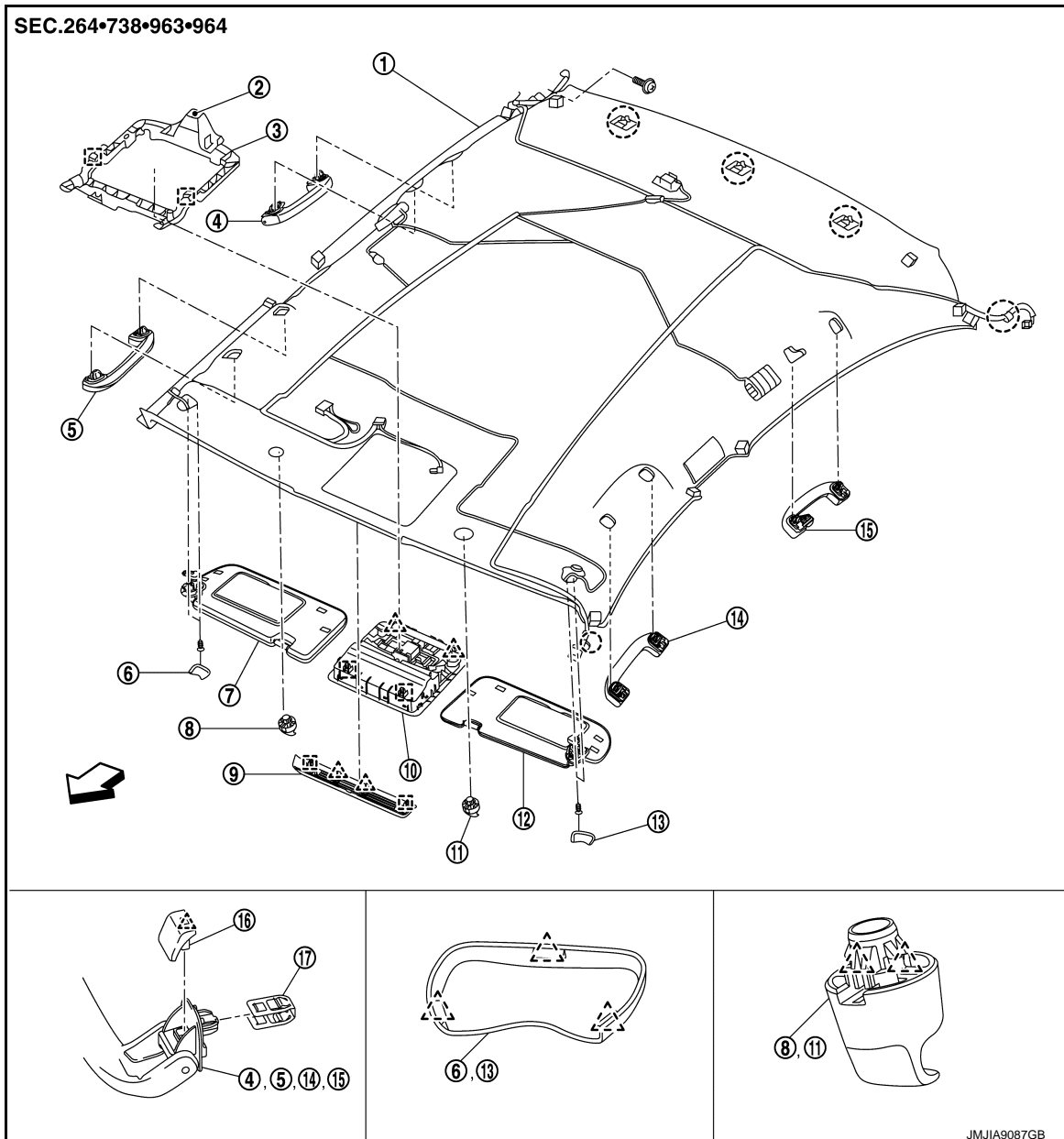

- |                         |                        |                         |
|-------------------------|------------------------|-------------------------|
| ① Headlining assembly   | ② Dual lock fastener   | ③ Map lamp bracket      |
| ④ Rear assist grip RH   | ⑤ Front assist grip RH | ⑥ Sun visor cover RH    |
| ⑦ Sun visor assembly RH | ⑧ Sun visor holder RH  | ⑨ Inside mirror cover   |
| ⑩ Map lamp assembly     | ⑪ Sun visor holder LH  | ⑫ Sun visor assembly LH |
| ⑬ Sun visor cover LH    | ⑭ Front assist grip LH | ⑮ Rear assist grip LH   |
| ⑯ Assist grip cap       | ⑰ Metal clip           |                         |

- : Clip
- △ : Pawl
- : Metal clip
- ← : Vehicle front

JMJIA9087GB



# HEADLINING

< REMOVAL AND INSTALLATION >

Sunroof models

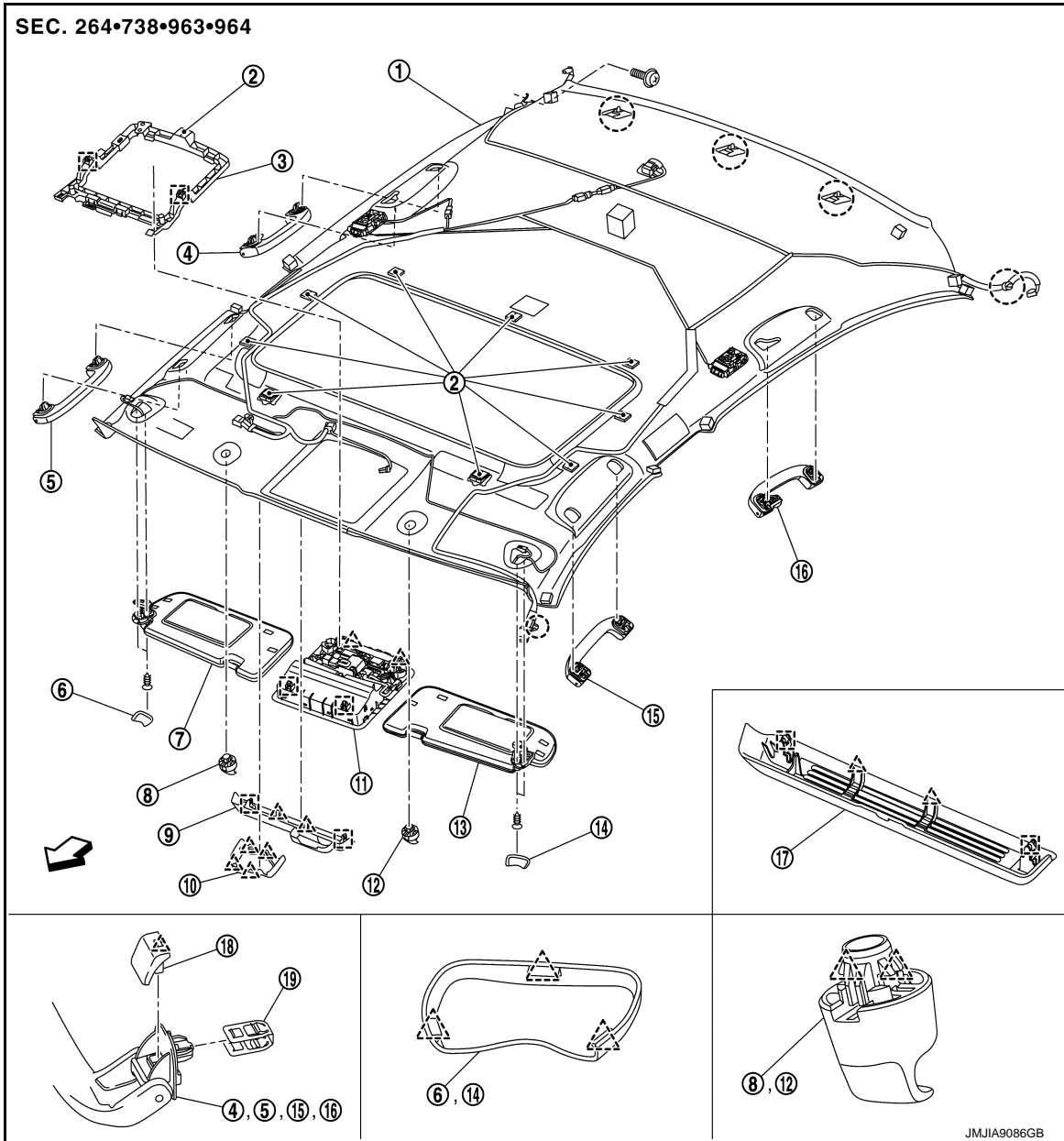

- ① Headlining assembly
  - ② Dual lock fastener
  - ③ Map lamp bracket
  - ④ Rear assist grip RH
  - ⑤ Front assist grip RH
  - ⑥ Sun visor cover RH
  - ⑦ Sun visor assembly RH
  - ⑧ Sun visor holder RH
  - ⑨ Inside mirror cover (with rain sensor)
  - ⑩ Rain sensor cover (with rain sensor)
  - ⑪ Map lamp assembly
  - ⑫ Sun visor holder LH
  - ⑬ Sun visor assembly LH
  - ⑭ Sun visor cover LH
  - ⑮ Front assist grip LH
  - ⑯ Rear assist grip LH
  - ⑰ Inside mirror cover (without rain sensor)
  - ⑱ Assist grip cap
  - ⑲ Metal clip
- : Clip  
 △ : Pawl  
 □ : Metal clip  
 ← : Vehicle front

A  
B  
C  
D  
E  
F  
G  
H  
I  
INT  
K  
L  
M  
N  
O  
P

JMJIA9086GB

# HEADLINING

## < REMOVAL AND INSTALLATION >

### Removal and Installation

INFOID:000000011281445

#### CAUTION:

- When removing, always use a remover tool that is made of plastic to prevent damage to the parts.
- Never damage the roof panel.



#### REMOVAL

1. Remove map lamp assembly. Refer to [INL-63, "MAP LAMP : Removal and Installation"](#).
2. Disengage rain sensor cover fixing pawls, and then remove rain sensor cover (with rain sensor).

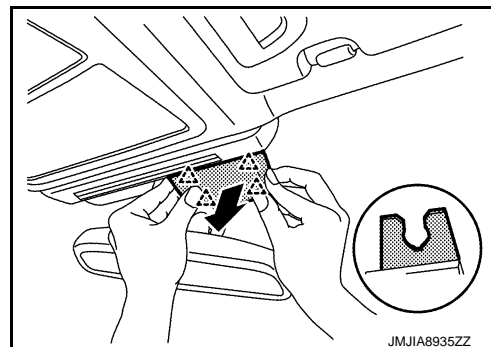
 : Pawl



3. Disengage inside mirror cover fixing pawls and metal clips, and then remove inside mirror cover.

 : Pawl  
 : Metal clip

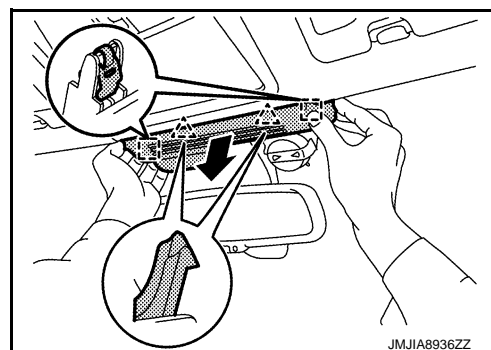

4. Remove front pillar garnish (LH and RH). Refer to [INT-24, "FRONT PILLAR GARNISH : Removal and Installation"](#).
5. Remove the following parts of front pillar LH.
  - Disconnect harness connector **A**.
  - Disconnect harness connector **B** (if equipped).
  - Disengage harness fixing clip (if equipped).

 : Clip

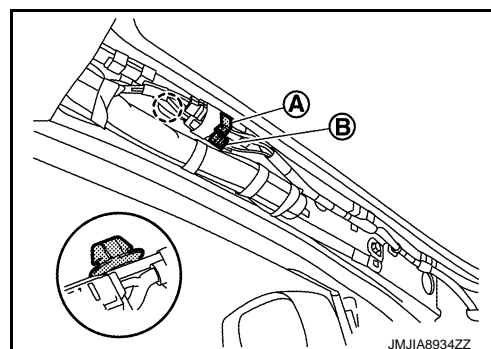

6. Remove center pillar upper garnish (LH and RH). Refer to [INT-29, "CENTER PILLAR UPPER GARNISH : Removal and Installation"](#).
7. Remove rear pillar finisher (LH and RH). Refer to [INT-31, "REAR PILLAR FINISHER : Removal and Installation"](#).

# HEADLINING

## < REMOVAL AND INSTALLATION >

8. Remove the following parts of rear pillar LH.

- Disconnect harness connector (A).
- Disengage harness fixing clip.

 : Clip

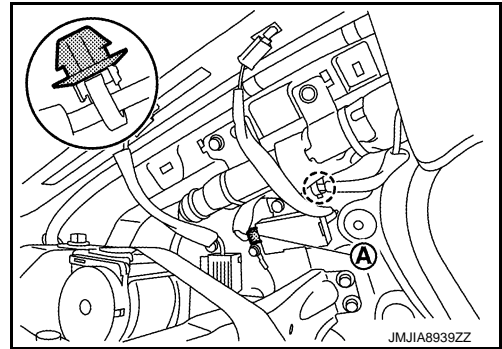

9. Remove the following parts of rear pillar RH.

- Remove mounting bolt (A).
- Disconnect harness connector (B) (if equipped).
- Disconnect harness connector (C).

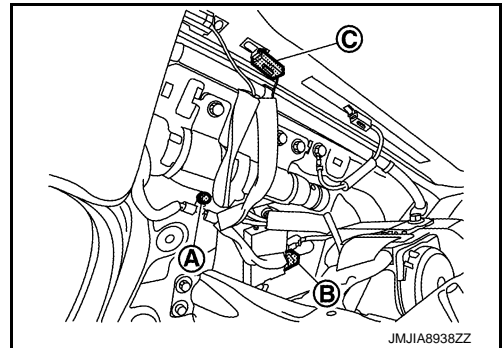

10. Remove front seat assembly (LH and RH). Refer to [SE-79, "Removal and Installation"](#).

11. Remove center console assembly. Refer to [IP-24, "Removal and Installation"](#).

12. Remove rear seatback. Refer to the following.

- Bench seat models: [SE-97, "SEATBACK : Removal and Installation"](#).
- 6 : 4 separate seat models: [SE-103, "SEATBACK : Removal and Installation"](#).

13. Remove front body side welt (LH and RH) and rear body side welt (LH and RH). Refer to [INT-28, "BODY SIDE WELT : Removal and Installation"](#).

14. Remove all assist grips.

a. Disengage assist grip cap fixing pawl using a remover tool (A), and then slide assist grip cap and remove it according to numerical order 1→2 indicated by arrows in the figure.

 : Pawl

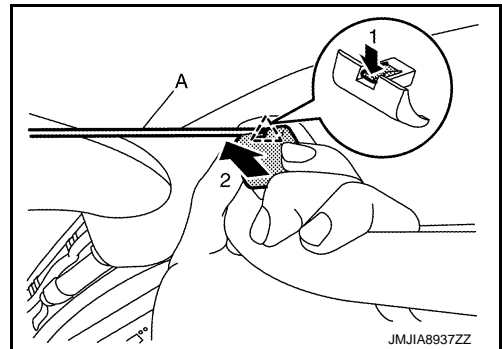

b. Slide assist grip forward and remove it.

15. Remove sun visor assembly (LH and RH).

a. Disengage sun visor cover fixing pawls using a remover tool (A), and then remove sun visor cover (LH and RH).

 : Pawl

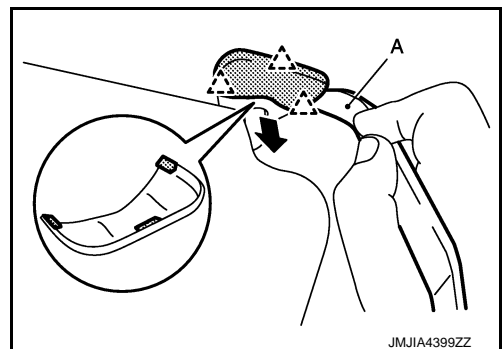

b. Remove sun visor assembly fixing screws, and then disconnect vanity mirror lamp harness connector.

# HEADLINING

## < REMOVAL AND INSTALLATION >

- c. Remove sun visor assembly (LH and RH).
16. Remove sun visor holder (LH and RH) using a remover tool according to numerical order 1→2 indicated by arrows as shown in the figure.

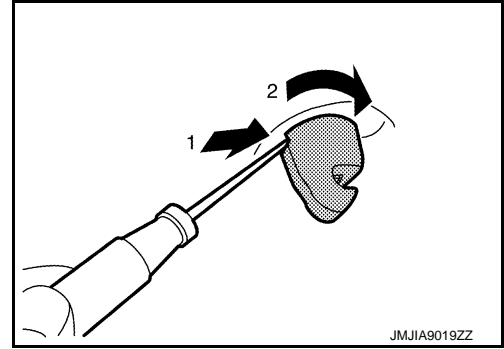

17. Peel off dual lock fasteners (A) between headlining assembly and roof panel (with sunroof).
- CAUTION:**  
Never bend headlining when removing.

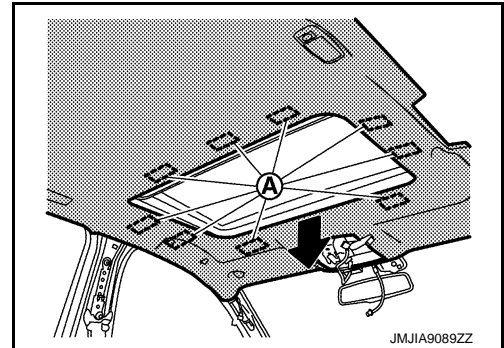

18. Slide headlining toward vehicle front, and then remove headlining.
- CAUTION:**
- Two workers are required for removal in order to prevent damage.
  - Never bend headlining when removing.
  - When removing headlining assembly, fixing clips remain on roof panel. After removing headlining assembly, remove the fixing clips from roof panel.

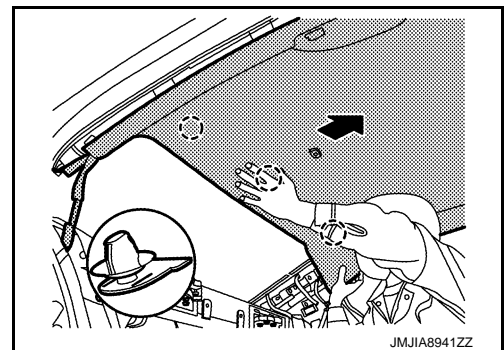

 : Clip

19. Remove headlining assembly from rear passenger side according to direction indicated by the arrow as shown in the figure.
- CAUTION:**
- Two workers are required for removal in order to prevent damage.
  - Apply protective tape to the portion where contact may occur during work.
  - Never bend headlining when removing.

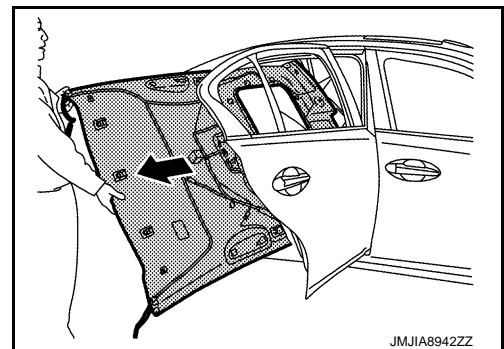

20. Remove the following parts after removing headlining assembly.
- Antenna feeder. Refer to [AV-286, "Feeder Layout"](#).
  - Personal lamp assembly. Refer to [INL-73, "Removal and Installation"](#).

## INSTALLATION

Note the following items, and then install in the reverse order of removal.

- CAUTION:**
- Install headlining assembly after inserting clips to clip holder of headlining rear end.
  - Never bend headlining when installing.
  - Be careful that the surface is not wrinkled when installing.

# HEADLINING

## < REMOVAL AND INSTALLATION >

- When installing assist grip, install metal clip ① to assist grip clip ②, and then install to the body panel.

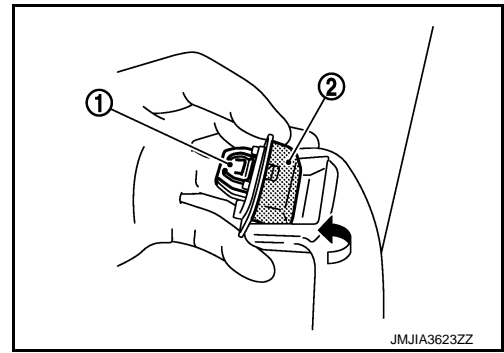

A  
B  
C  
D  
E  
F  
G  
H  
I

INT

K  
L  
M  
N  
O  
P

# TRUNK ROOM TRIM

< REMOVAL AND INSTALLATION >

## TRUNK ROOM TRIM

Exploded View

INFOID:000000011281446

Bench seat models

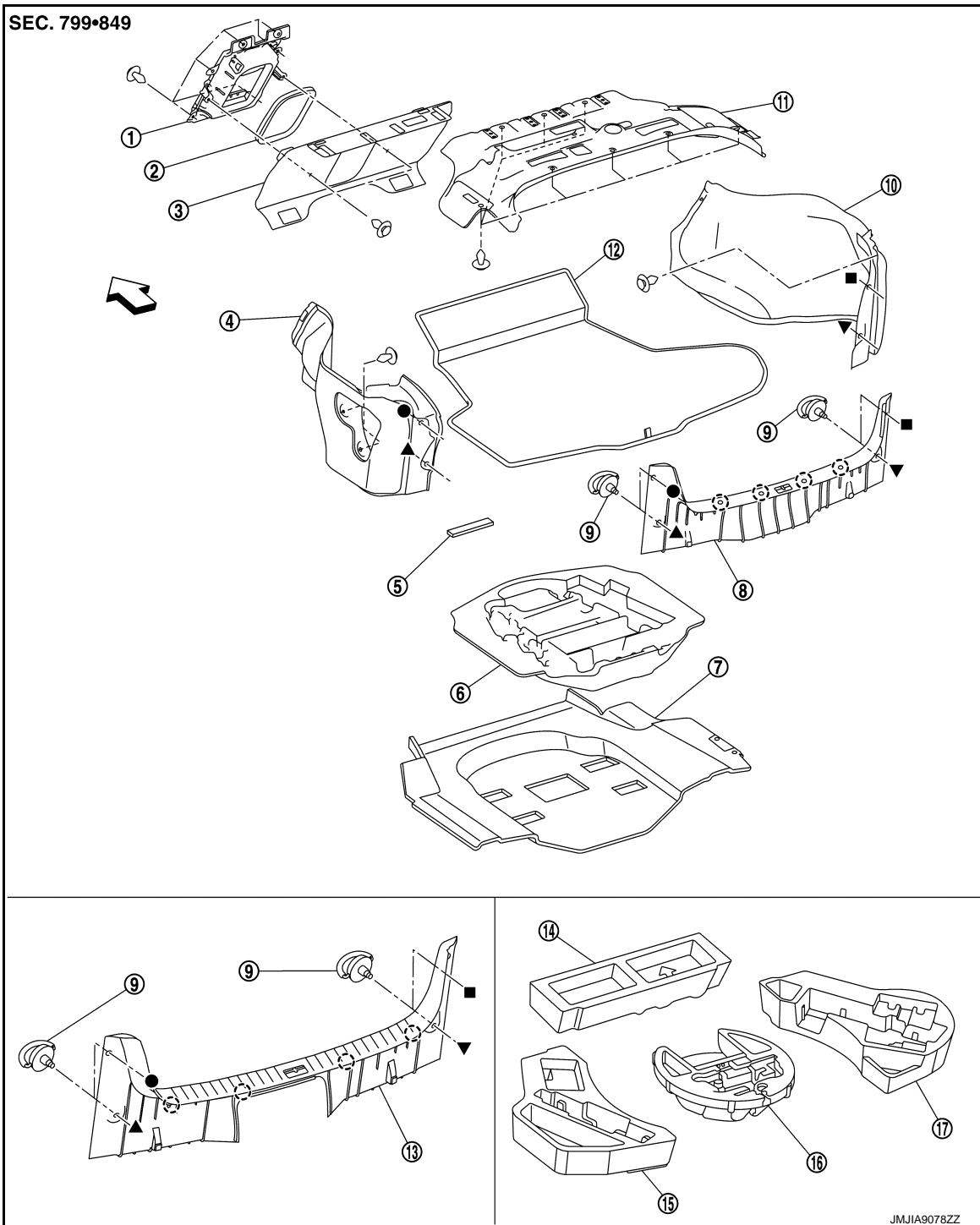

- |                                  |  |  |
|----------------------------------|--|--|
| ① Rear seatback center finisher  | ② Rear seatback welt                     | ③ Trunk front finisher                     |
| ④ Trunk side finisher LH         | ⑤ Trunk floor front spacer* <sup>1</sup> | ⑥ Trunk center box* <sup>1</sup>           |
| ⑦ Thinsulate                     | ⑧ Trunk rear plate* <sup>1</sup>         | ⑨ Trunk net hook                           |
| ⑩ Trunk side finisher RH         | ⑪ Trunk upper finisher                   | ⑫ Trunk floor carpet                       |
| ⑬ Trunk rear plate* <sup>2</sup> | ⑭ Trunk floor front spacer* <sup>2</sup> | ⑮ Trunk floor rear spacer LH* <sup>2</sup> |

# TRUNK ROOM TRIM

## < REMOVAL AND INSTALLATION >

⑩ Trunk floor rear spacer center\*2

⑪ Trunk floor rear spacer RH\*2

○ : Clip

△ : Pawl

← : Vehicle front

●, ▲, ■, ▼: Indicates that the part is connected at points with same symbol in actual vehicle.

\*1: Without spare tire.

\*2: With spare tire.

6 : 4 separate seat models

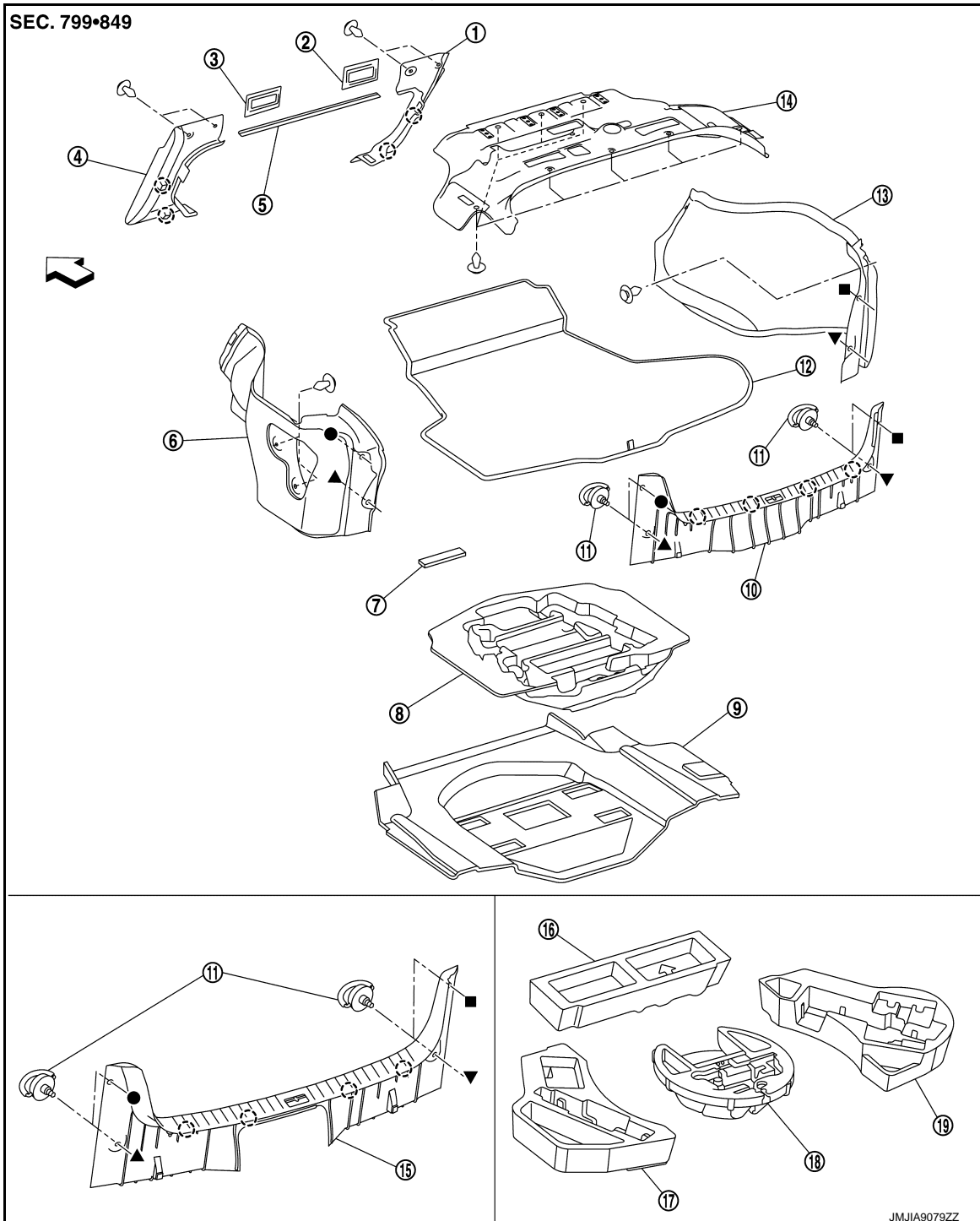

A  
B  
C  
D  
E  
F  
G  
H  
I  
INT  
K  
L  
M  
N  
O  
P

# TRUNK ROOM TRIM

## < REMOVAL AND INSTALLATION >

- |  |  |  |
|--|--|--|
| ① Rear seatback finisher RH              | ② Rear seat striker cover RH               | ③ Rear seat striker cover LH                   |
| ④ Rear seatback finisher LH              | ⑤ Rear seatback welt                       | ⑥ Trunk side finisher LH                       |
| ⑦ Trunk floor front spacer <sup>*1</sup> | ⑧ Trunk center box <sup>*1</sup>           | ⑨ Thinsulate                                   |
| ⑩ Trunk rear plate <sup>*1</sup>         | ⑪ Trunk net hook                           | ⑫ Trunk floor carpet                           |
| ⑬ Trunk side finisher RH                 | ⑭ Trunk upper finisher                     | ⑮ Trunk rear plate <sup>*2</sup>               |
| ⑯ Trunk floor front spacer <sup>*2</sup> | ⑰ Trunk floor rear spacer LH <sup>*2</sup> | ⑱ Trunk floor rear spacer center <sup>*2</sup> |

○ : Clip

△ : Pawl

↔ : Vehicle front

●, ▲, ■, ▼: Indicates that the part is connected at points with same symbol in actual vehicle.

\*: Without spare tire.

\*: With spare tire.

## TRUNK REAR PLATE

### TRUNK REAR PLATE : Removal and Installation

INFOID:000000011281447

#### CAUTION:

- When removing, always use a remover tool that is made of plastic to prevent damage to the parts.
- Never damage the body panel.

#### REMOVAL

1. Fully open trunk lid.
2. Remove trunk floor carpet.
3. Remove trunk center box (without spare tire).
4. Remove trunk floor rear spacer (LH and RH) (with spare tire).
5. Remove trunk net hooks ① using a remover tool (A).

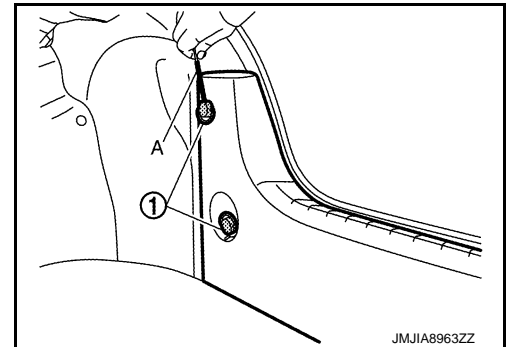

6. Disengage fixing clips using a remover tool (A), and then remove trunk rear plate.

○ : Clip

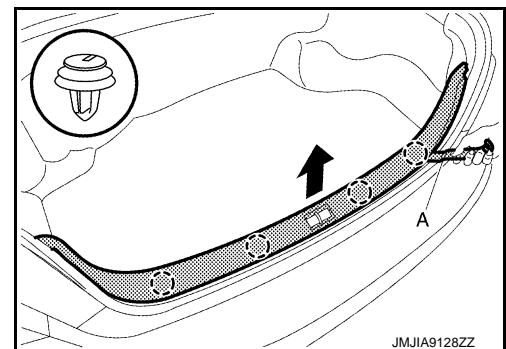

#### INSTALLATION

Note the following items, and then install in the reverse order of removal.

#### CAUTION:



# TRUNK ROOM TRIM

## < REMOVAL AND INSTALLATION >

- Visually check clips for deformation and damage during installation. Replace with new ones if necessary.
- When installing, check in advance that clips are accurately aligned with the portions on body panel, and then install by pressing in.

### TRUNK FRONT FINISHER

#### TRUNK FRONT FINISHER : Removal and Installation

INFOID:000000011281448

#### **CAUTION:**

Never damage the body panel.

#### REMOVAL

1. Remove trunk side finisher (LH and RH). Refer to [INT-49, "TRUNK SIDE FINISHER : Removal and Installation"](#).
2. Remove trunk front finisher fixing clips (A) and disengage dual-lock fasteners (B), and then remove trunk front finisher.

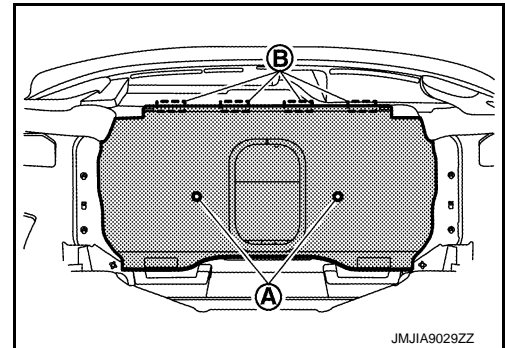

#### INSTALLATION

Note the following items, and then install in the reverse order of removal.

#### **CAUTION:**

- Visually check clips for deformation and damage during installation. Replace with new ones if necessary.
- When installing, check in advance that clips are accurately aligned with the portions on rear seat-back support, and then install by pressing in.

### TRUNK SIDE FINISHER

#### TRUNK SIDE FINISHER : Removal and Installation

INFOID:000000011281449

#### **CAUTION:**

Never damage the body panel.

#### REMOVAL

1. Remove trunk rear plate. Refer to [INT-48, "TRUNK REAR PLATE : Removal and Installation"](#).
2. Remove trunk floor front spacer.
3. Remove trunk weather-strip. Refer to [DLK-213, "TRUNK LID WEATHER-STRIP : Removal and Installation"](#).
4. Remove trunk side finisher fixing clip (A), and then remove trunk side finisher RH.

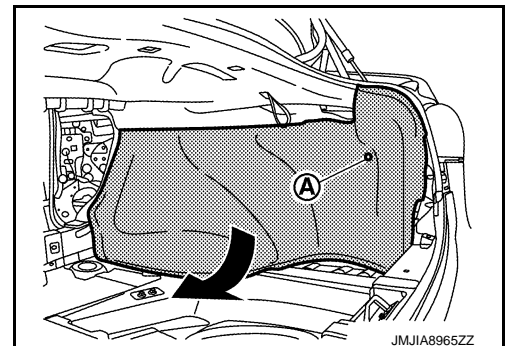

# TRUNK ROOM TRIM

## < REMOVAL AND INSTALLATION >

5. Remove trunk side finisher fixing clips (A), and then remove trunk side finisher LH.

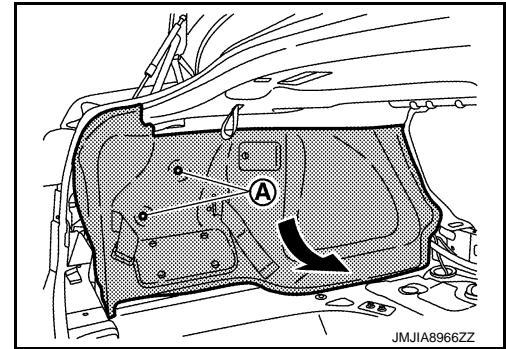

## INSTALLATION

Note the following items, and then install in the reverse order of removal.

### CAUTION:

- Insert rear end of trunk side finisher into trunk weather-strip.
- Visually check clips for deformation and damage during installation. Replace with new ones if necessary.
- When installing, check in advance that clips are accurately aligned with the portions on body panel, and then install by pressing in.

## TRUNK UPPER FINISHER

### TRUNK UPPER FINISHER : Removal and Installation

INFOID:000000011281450

### CAUTION:

Never damage the body panel.

## REMOVAL

1. Remove trunk side finisher (LH and RH). Refer to [INT-49, "TRUNK SIDE FINISHER : Removal and Installation"](#).
2. Remove trunk front finisher. Refer to [INT-49, "TRUNK FRONT FINISHER : Removal and Installation"](#) (Bench seat models).
3. Remove trunk upper finisher fixing clips (A), and then remove trunk upper finisher.

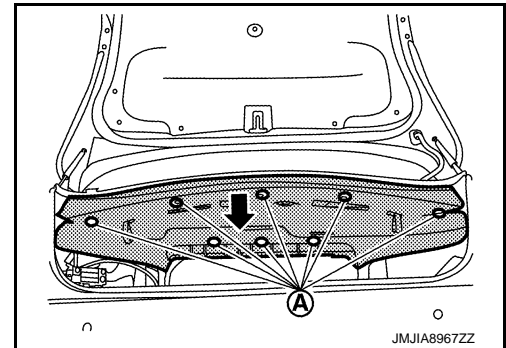

## INSTALLATION

Note the following items, and then install in the reverse order of removal.

### CAUTION:

- Visually check the clips for deformation and damage during installation. Replace with new ones if necessary.
- When installing, check in advance that clips are accurately aligned with the portions on body panel, and then install by pressing in.

## REAR SEATBACK FINISHER

### REAR SEATBACK FINISHER : Removal and Installation

INFOID:000000011281451

### CAUTION:

- When removing, always use a remover tool that is made of plastic to prevent damage to the parts.
- Never damage the body.

# TRUNK ROOM TRIM

## < REMOVAL AND INSTALLATION >

### REMOVAL

Bench Seat Models

1. Remove trunk front finisher fixing clips (A).

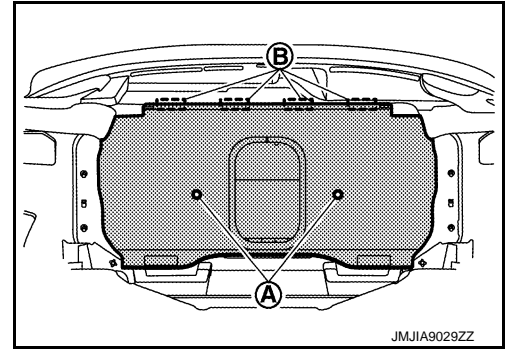

2. Remove rear seatback assembly. Refer to [SE-97, "SEATBACK : Removal and Installation"](#).
3. Remove rear seatback center finisher fixing clips (A), and then remove rear seatback center finisher.

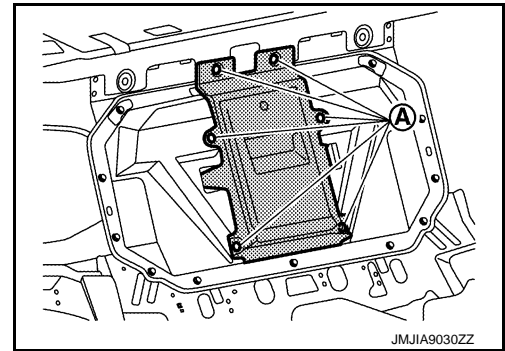

4. Remove rear seatback welt, after removing rear seatback center finisher.

6 : 4 Separate Seat Models

1. Pull the strap to fold rear seatback down. Refer to [SE-103, "SEATBACK : Removal and Installation"](#).
2. Remove rear seatback side. Refer to [SE-103, "SEATBACK : Removal and Installation"](#).
3. Remove rear seatback finisher.
- a. Remove rear seatback finisher fixing clips (A).

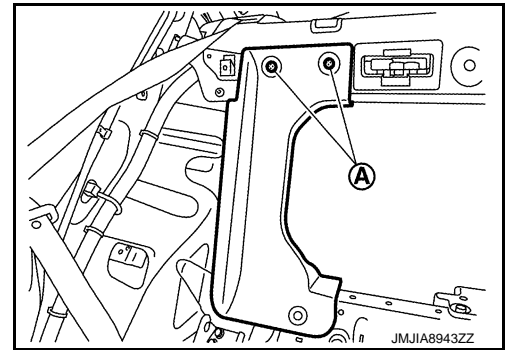

- b. Disengage rear seatback finisher fixing clips using a remover tool (A), and then remove rear seatback finisher.

 : Clip

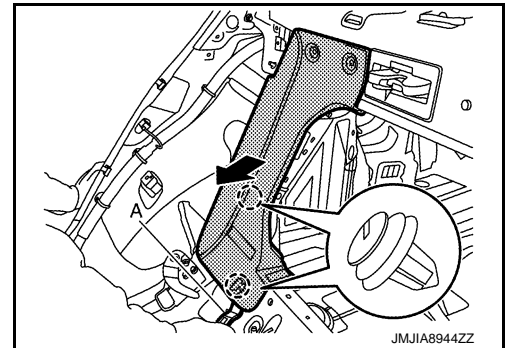

A  
B  
C  
D  
E  
F  
G  
H  
I  
INT

K  
L  
M  
N  
O  
P

## TRUNK ROOM TRIM

### < REMOVAL AND INSTALLATION >

4. Remove rear seatback welt after removing rear seatback finisher (LH and RH).

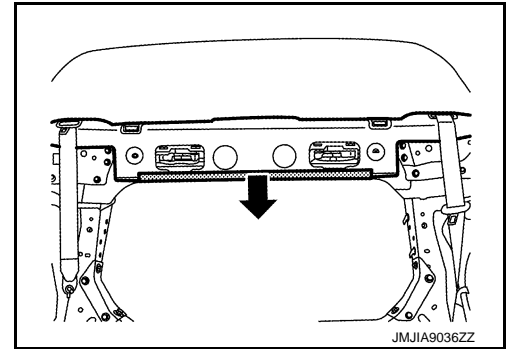

### INSTALLATION

Note the following items, and install in the reverse order of removal.

#### **CAUTION:**

- Visually check clips for deformation and damage during installation. Replace with new ones if necessary.
- When installing, check in advance that clips are accurately aligned with the portions on body panel, and then install by pressing in.

### REAR SEAT STRIKER COVER

#### REAR SEAT STRIKER COVER : Removal and Installation

INFOID:000000011281452

#### **CAUTION:**

- When removing, always use a remover tool that is made of plastic to prevent damage to the parts.
- Never damage the body panel and rear parcel shelf finisher.

### REMOVAL

1. Pull the strap to fold seatback down. Refer to [SE-103. "SEATBACK : Removal and Installation"](#).
2. Disengage rear seat striker cover fixing pawls using a remover tool (A), and then remove rear seat striker cover.

 : Pawl

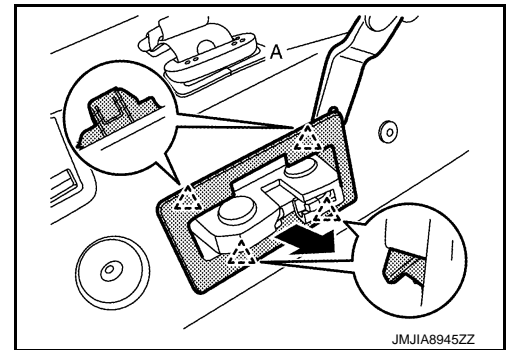

### INSTALLATION

Install in the reverse order of removal.

# TRUNK LID TRIM

< REMOVAL AND INSTALLATION >

## TRUNK LID TRIM

Exploded View

INFOID:000000011281453

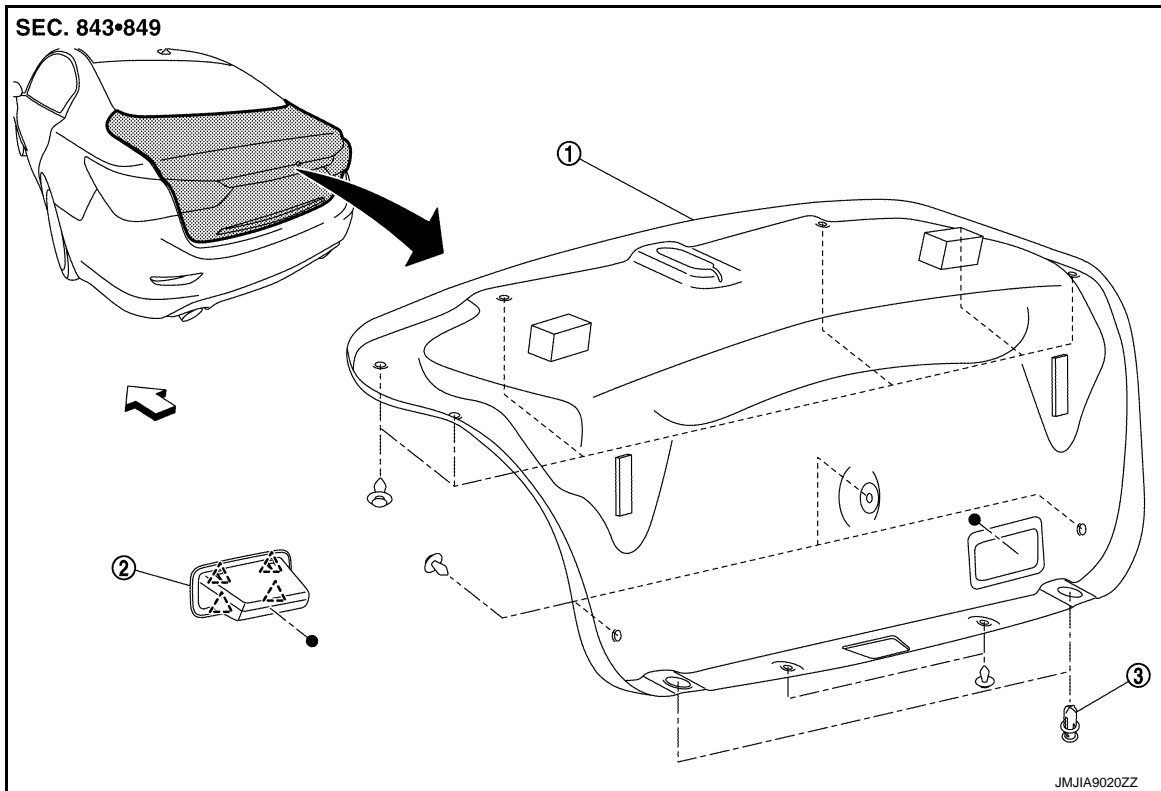

① Trunk lid inner finisher

② Trunk lid pull handle

③ Lift spring

△ : Pawl

← : vehicle front

● : Indicates that the part is connected at points with same symbol in actual vehicle.

## Removal and Installation

INFOID:000000011281454

### CAUTION:

- When removing, always use a remover tool that is made of plastic to prevent damage to the parts.
- Never damage the trunk lid.

### REMOVAL

1. Fully open trunk lid assembly.
2. Remove trunk lid inside handle and trunk lid inside handle holder. Refer to [DLK-232, "TRUNK LID LOCK : Removal and Installation"](#).
3. Remove trunk lid lift spring. Refer to [DLK-232, "TRUNK LID LOCK : Removal and Installation"](#).
4. Disengage trunk lid pull handle fixing pawls using a remover tool (A), and then remove trunk lid pull handle.

△ : Pawl

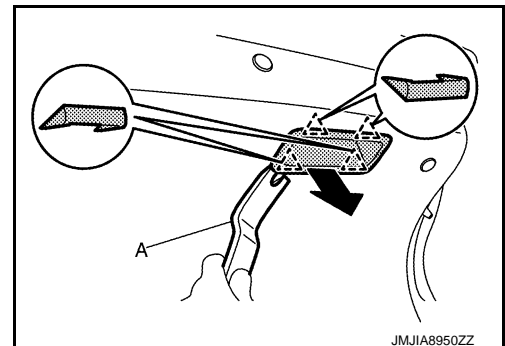

## TRUNK LID TRIM

### < REMOVAL AND INSTALLATION >

5. Remove trunk lid inner finisher fixing clips (A), and then remove trunk lid inner finisher.

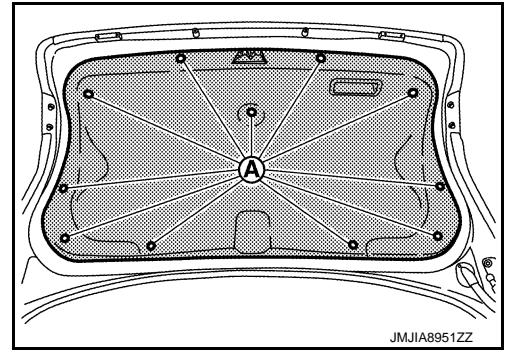

### INSTALLATION

Note the following items, and then install in the reverse order of removal.

#### **CAUTION:**

- Visually check clips for deformation and damage during installation. Replace with new ones if necessary.
- When installing, check in advance that clips and pawls are accurately aligned with the portions on body panel, and then install by pressing in.
- When installing trunk lid pull handle, confirm the front and rear direction of trunk lid pull handle.